



SBI INFRA MANAGEMENT SOLUTIONS PVT. LTD.
CIRCLE OFFICE, AHMEDABAD
STATE BANK OF INDIA, 3RD FLOOR, LOCAL HEAD OFFICE, BHADRA,
LALDARWAJA, AHMEDABAD-380001

SBIIMS INVITE TENDERS ON BEHALF OF SBI FOR PROPOSED FURNISHING
WORKS FOR PARLEPOINT BRANCH AT PARLEPOINT, SUART DISTT- SURAT

Tender ID : AHM201906006

FROM

THE SBI APPROVED EMPANELLED FURNITURE CONTRACTORS UNDER
CATEGORY – F2 TO F6 ONLY

PART – A: TECHNICAL BID

TENDER SUBMITTED BY:

NAME : _____

ADDRESS : _____

DATE : _____

ARCHITECT:

AR. VISHAL PAREKH
409, KINARO APPARTMENT, NEAR MAKKAI POOL
NANPURA, SURAT – 390 008
MOBILE – 9879317886
EMAIL – vishalvparekh@yahoo.com

INDEX

Tender documents are in two parts (Volumes) i.e. Part - A and Part - B
PART - A (TECHNICAL BID)

Sr. No.	Description	Page No.
1	<i>Cover page</i>	1
2	<i>Index</i>	2
3	<i>Notice Inviting Tender</i>	3
4	<i>Form of Tender</i>	6
5	<i>Articles of Agreement</i>	14
6	<i>Instructions to the Tenderers</i>	19
7	<i>General Conditions of Contract</i>	23
8	<i>Appendix Herein Before Referred To</i>	49
9	<i>Letter Of Declaration</i>	51
10	<i>Pro-forma For Running A/C Bill</i>	53
11	<i>Technical Specifications</i>	57
12	<i>Important points to be noted</i>	69
13	<i>Approved make List</i>	72
14	<i>Bill of Quantities (Not to be filled)</i>	78
15	<i>Tender drawings & Details (16 nos. Drawings)</i>	92

Tender ID : AHM201906006

NOTICE INVITING TENDERS

SBIIMS on behalf of SBI through its Architect **M/s Vishal Parekh, Surat** invites “online item rate E-tender” from the SBI Empanelled contractors under appropriate category for the captioned work.

The details of tender are as under:

S.No.	Description	
1.	Name of work	PROPOSED FURNITURE WORK IN EXISTING PREMISES FOR STATE BANK OF INDIA PARLEPOINT BRANCH, Surat
2.	Nature of Work	Loose and Fixed Furniture works
3.	Time allowed for completion	(30 days) 1 Month from date of acceptance of work order or hand-over of site
4.	Application/ Tender fees	Rs 1000 (Rupees. One Thousand Only) Non-refundable AMOUNT TO BE PAID ONLY THROUGH SB COLLECT PAYMENT PORTAL AVAILABLE IN SBI site https://www.onlinesbi.com) <u>GUIDELINES TO MAKE ONLINE TENDER FEES</u> go to SBI Internet Banking website- https://www.onlinesbi.com/ ↓ Select SBI Collect from Top Menu ↓ Click Check box to Proceed

		<p style="text-align: center;">↓</p> <p>Select "All India " in state Corporate/Institution and "Commercial Services" in type of Corporate / Institution after that click go</p> <p style="text-align: center;">↓</p> <p>Select " SBI INFRA MANAGEMENT SOLUTIONS PVT. LTD." IN Commercial Services Name and Submit</p> <p style="text-align: center;">↓</p> <p>Select "Tender Application Fee" in Payment category and Enter "Tender ID " and Submit</p> <p style="text-align: center;">↓</p> <p>The Vendor will have to fill up the fields properly and submit upon making the payment a receipt will be generated with a reference no. on submit. The Contractor has to enclose the receipt along with EMD in Technical Price.</p>
5.	Period of deposit of tender Fees (online) in SB collect*	15-06-2019 to 29-06-2019
6.	Earnest Money Deposit	Rs.7,000 (Seven Thousand only) by means of Demand Draft / Banker's Cheque (Valid for a period of 90 Days from the last date of submission of the tender) from any scheduled Nationalized Bank drawn in favour of SBI Infra Management Solutions Pvt. Ltd. and payable at Ahmedabad.
7.	Initial Security Deposit	2% of contract amount including EMD
8.	Total Security deposit	5% of the final bill amount including ISD.
9.	Start and end date for downloading of tender documents form Bank's website	15-06-2019 to 29-06-2019 at www.sbi.co.in under<Link>procurement news.
10.	Last date & time for submission of Technical bid, EMD and receipt of deposit of tender fees.	01-07-2019 by 3 PM

11.	Address at which Technical bid (hard copy) along with EMD & Application fees in cover A has to be submitted	Circle Head & Vice President, SBI Infra Management Solutions Pvt. Ltd. Third Floor, SBI, LHO, Bhadra, Laldarwaja Ahmedabad-380001
12.	Date and time of opening of Technical bid at SBIIMS, Circle Office address mentioned at Sr. No.11	01-07-2019 by 3.30 PM
13.	Date & time for submission of online indicative price bid.	Date and time for submission of indicative price bid will be informed to the qualified contractor separately after scrutiny of their Technical bid.
14.	Date & time for opening of online indicative price bid.	Date and time will be informed to the qualified contractor separately.
15.	Date & time for e-reverse auction	Date and time for e-reverse auction will be informed to the qualified contractor separately.
16.	Liquidated Damages	0.50% of contract amount per weeks subject to max. 5% of contract value or final bill value.
17.	Defects liability period	12 Months from the date of Virtual Completion
18.	Validity of offer	180 days from the date of opening of Price-bid
19.	Value of Interim Certificate	Only full & final payment will be paid. No advance on materials / plant / machinery or mobilization advance shall be paid under any circumstances

*** Fee paid beyond the permitted period will be rejected.**

19. Tenders can be downloaded from the bank's website www.sbi.co.in (link) <Procurement News>. It shall be responsibility of the contractor to arrange and ensure that all pages of technical and financial bid are properly bound separately. Tenders in loose pages may be disqualified.
20. The contractor shall sign and stamp each page of the tender document thereby ensuring the number and sequence of all pages.
21. No conditions other than mentioned in the tender will be considered and if given they will have to be withdrawn before opening of the price-bid.
22. The SBIIMS reserve their rights to accept or reject any or all the tenders, either in whole or in part without assigning any reason(s) for doing so and no claim / correspondence shall be entertained in this regard.
23. Tenders received without EMD and Application Fees shall be summarily rejected and such tenders shall not be allowed to participate in the online price bidding process.
24. In case the date of opening of tenders is declared as a holiday, the tenders will be opened on the next working day at the same time.
25. SBIIMS has the right to accept / reject any / all tenders without assigning any reasons and no correspondence shall be entertained in this regard.

Yours Faithfully,

For:
Ar. Vishal Parekh
409, Kinaro, Near Makkai Pool,
Nanpura,
Surat – 390 008

FORM TENDER

To,
The Circle Head
& VP (Civil),
Circle Office,
SBI Infra Management
Solutions Pvt. Ltd.,
Ahmedabad- 380001.

Dear Sir,

Having examined the drawings, specification, design and schedule of quantities relating to the works specified in the memorandum hereinafter set out and having visited and examined the site of the works specified in the said memorandum and having acquired the requisite information relating thereto as affecting the tender, I/We hereby offer to execute the works specified in the said memorandum at the rates mentioned in the attached Schedule of Quantities and in accordance in all respects with the specifications, design, drawings and instructions in writing referred to in conditions of tender, the Articles of Agreement, Special Conditions, Schedule of Quantities and Conditions of Contract and with such materials as are provided for by, and in all other respects in accordance with such conditions so far as they may be applicable.

MEMORANDUM

Description of work	Proposed Furnishing works at existing premises of State Bank of India Parlepoint Branch, Surat
Earnest Money	Rs.7,000 (Seven Thousand only) by means of Demand Draft / Pay Order (Valid for a period of 90 Days from the last date of submission of the tender) from any scheduled Nationalized Bank drawn in favour of SBI Infra Management Solutions Pvt. Ltd. and payable at Ahmedabad.
Percentage, if any, to be deducted from Bills and total amount to be retained	10 % from Running Bills, subject to maximum Total 5% of contract amount or actual Final Bill value including EMD & Initial Security Deposit.
Time allowed for completion of the Works from fourteenth day after the date of written order or date of handing over of the site (whichever is later) to commence the work	30 days

I/We have deposited a sum of **Rs.7,000 (Rupees Seven Thousand only)** of the total tender amount as Earnest Money with the SBIIMS which is not to bear any interest. Should I / We fail to execute the Contract when called upon to do so I/

We do hereby agree that this sum shall be forfeited by me/us to SBI Infra Management Solutions.

1) Our Bankers are: i)

ii)

The names of partners of our firm are: i)

ii)

Name of the partner of the firm Authorized to sign

Or

(Name of person having Power of Attorney to sign the Contract.)

(Certified true copy of the Power of Attorney should be attached)

Yours faithfully,

Signature of Contractors.

Signature and addresses of Witnesses

i)

ii)

SAMPLE BUSINESS RULE DOCUMENT

ONLINE E-TENDERING FOR PROPOSED FURNISHING WORKS FOR PARLEPOINT BRANCH AT PARLEPOINT DIST. SURAT

(A) Business rules for E-tendering:

1. Only empanelled Furnishing contractors with SBI under appropriate category who are invited by the project Architect/SBIIMS shall only be eligible to participate.
2. SBIIMS will engage the services of an E-tendering service provider who will provide necessary training and assistance before commencement of online bidding on Internet.
3. In case of e-tendering, SBIIMS will inform the vendor in writing, the details of service provider to enable them to contact and get trained.
4. Business rules like event date, closing and opening time etc. also will be communicated through service provider for compliance.
5. Contractors have to send by email, the compliance form in the prescribed format (provided by service provider), before start of E-tendering. Without this the vendor will not be eligible to participate in the event.
6. The Contractors will be required to submit the various documents in sealed Envelope to the office of SBI Infra Solutions Pvt Ltd. at the address mentioned hereinbefore by the stipulated date i.e. (1) Hard Copy of Technical Bid duly signed and stamped on each page (2) Demand Draft of specified amount of EMD (3) Demand Draft / Cheque of Application Fees (4) Certified copy of Work Licenses). Contractors not submitting any one or more documents shall not be eligible to participate in the on-line price bidding.
7. E-tendering will be conducted on schedule date & time.
8. **The e-tendering will be treated as closed only when the bidding process gets closed in all respects for the item listed in the tender.**

(B) Terms & conditions of E-tendering:

SBIIMS shall finalize the Tender through e-tendering mode for which **M/s. eProcurement Technology, Ahmedabad** has been engaged by SBIIMS as an authorized service provider. Please go through the guidelines given below and submit your acceptance to the same along with your Commercial Bid.

1. E-tendering shall be conducted by SBIIMS through **M/s. e-Procurement Technology, Ahmedabad**, on pre-specified date. While the Contractors shall be quoting from their own offices/ place of their choice, Internet connectivity and other paraphernalia requirements shall have to be ensured by Contractors themselves. In the event of failure of their Internet connectivity, (due to any reason whatsoever it may be) it is the bidders' responsibility.



In order to ward-off such contingent situation bidders are requested to make all the necessary arrangements / alternatives such as back-up power supply whatever required so that they are able to circumvent such situation and still be able to participate in the Etendering successfully. Failure of power at the premises of Contractors during the Etendering cannot be the cause for not participating in the E-tendering. On account of this the time for the E-tendering cannot be extended and SBIIMS is not responsible for such eventualities.

2. M/s. **e-Procurement Technology, Ahmedabad.**, shall arrange to train your nominated person(s), without any cost to you. They shall also explain you all the Rules related to the E- tendering. You are required to give your compliance on it before start of bid process.
3. **Bidding currency and unit of measurement:** Bidding will be conducted in Indian currency & Unit of Measurement will be displayed in Online E-tendering.
4. **Bid Price:** The Bidder has to quote the rate as per the Tender Document provided by SBIIMS/ their appointed Architects.
5. **Validity of Bids:** The Bid price shall be firm for a period specified in the tender document and shall not be subjected to any change whatsoever.
6. **Procedure of E-tendering:**
 - i. **Online E-tendering:**
 - (a) The hard copy of the Technical as well as Price Bid is available on the Bank's website during the period specified in the NIT.
 - (b) Online e-tendering is open to the empanelled bidders who receive NIT from the Architect and qualified for participating in the price bidding as provisions mentioned hereinabove through SBIIMS approved Service Provider.
 - (c) The Price-Bid shall be made available online by the Service Provider wherein the contractors will be required to fill-in their Item-wise rates for each item.
 - (d) The Contractors are advised not to wait till the last minute to submit their online item-wise quote in the price bid to avoid complications related with internet connectivity, network problems, system crash down, power failure, etc.
 - (e) It is mandatory to all the bidders participating in the price bid to quote their rates for each and every item.

(f) In case, contractor fails to quote their rates for any one or more tender items, their tender shall be treated as **“Incomplete Tender”** and shall be liable for rejection.

7. **Log in Name and Password:** Each Bidder is assigned a Unique User Name & Password by M/s. **e-Procurement Technology, Ahmedabad**. The Bidders are requested to change the Password after the receipt of initial Password from M/s. **e-Procurement Technology, Ahmedabad**. All bids made from the Login ID given to the bidder will be deemed to have been made by the bidder.
8. **Bids placed by bidder:** Bids will be taken as an offer to execute the work as specified. Bids once made, cannot be cancelled / withdrawn and the Bidder shall be bound to execute the work at the quoted bid price. In case the L-1 Bidder backs out or fail to complete the work as per the rates quoted, SBIIMS shall at liberty to take action as deemed necessary including de-paneling such contractors and forfeiting their EMD
9. At the end of the E-tendering, SBIIMS will decide upon the winner. SBIIMS decision on award of Contract shall be final and binding on all the Bidders.
10. SBIIMS shall be at liberty to cancel the E-tendering process/tender at any time, before ordering, without assigning any reason.
11. SBIIMS shall not have any liability to bidders for any interruption or delay in access to the site irrespective of the cause.
12. Other terms and conditions shall be as per your techno-commercial offers and other correspondences till date.
13. **OTHER TERMS & CONDITIONS:**
 - The Bidder shall not involve himself or any of his representatives in Price manipulation of any kind directly or indirectly by communicating with other suppliers / bidders.
 - The Bidder shall not divulge either his Bids or any other exclusive details of SBIIMS to any other party.
 - SBIIMS decision on award of Contract shall be final and binding on all the Bidders.
 - SBIIMS reserve their rights to extend, reschedule or cancel any E-tendering within its sole discretion.

- SBIIMS or its authorized service provider M/s. **e-Procurement Technology, Ahmedabad** shall not have any liability to Bidders for any interruption or delay in access to the site irrespective of the cause.
- SBIIMS or its authorized service provider M/s. **e-Procurement Technology, Ahmedabad** is not responsible for any damages, including damages that result from, but are not limited to negligence.
- SBIIMS or its authorized service M/s. **e-Procurement Technology, Ahmedabad** will not be held responsible for consequential damages, including but not limited to systems problems, inability to use the system, loss of electronic information etc.

N.B.

- All the Bidders are required to submit the Process Compliance Statement (Annexure-II) duly signed to M/s. **e-Procurement Technology, Ahmedabad.**
- **All the bidders are requested to ensure that they have a valid digital signature certificate well in advance to participate in the online event.**



PROCESS COMPLIANCE STATEMENT (ANNEXURE II)

(The bidders are required to print this on their company's letter head and sign, stamp before emailing)

To,
M/s. **e-Procurement Technology**,
B-705, Wall Street - II, Opp. Orient Club, Ellis Bridge,
Ahmedabad – 380006,
State Gujarat, India

E:yashrajsinh@auctiontiger.net sujith@eptl.in web:- <https://etender.sbi>

D: +91 079-40270579/580/567/596, 079-40016815, 93745197554, 9879996111

Email:

AGREEMENT TO THE PROCESS RELATED TERMS AND CONDITIONS FOR THE ONLINE E-TENDERING FOR PROPOSED FURNISHING WORKS FOR PARLEPOINT BRANCH AT PARLEPOINT DIST. SURAT

Dear Sir,

This has reference to the Terms & Conditions for the E-tendering mentioned in the tender document

This letter is to confirm that:

- 1) The undersigned is authorized representative of the company.
- 2) We have studied the Commercial Terms and the Business rules governing the Etendering as mentioned in RFP of SBIIMS as well as this document and confirm our agreement to them.
- 3) We also confirm that we have taken the training on the E-tendering tool and have understood the functionality of the same thoroughly.
- 4) We confirm that SBIIMS and M/s. **e-Procurement Technology, Ahmedabad** shall not be liable & responsible in any manner whatsoever for my/our failure to access & bid on the e-E-tendering platform due to loss of internet connectivity, electricity failure, virus attack, problems with the PC, any other unforeseen circumstances etc. before or during the E- tendering event.
- 5) We confirm that we have a valid digital signature certificate issued by a valid Certifying Authority.

- 6) We, hereby confirm that we will honor the Bids placed by us during the E-tendering process.

Ar.Vishal Parekh

13

Sign and Seal of Contractor

With regards, Date:

Signature with company seal Name:

Company / Organization:

Designation within Company / Organization: Address of Company / Organization:

Scan it and send to this Document on -----

ARTICLES OF AGREEMENT

(On non-judicial Stamp Paper of Rs. 500 or as per latest Govt. Rules)

Articles of Agreement made this _____ day
of _____ between

State Bank Of India, a body, corporate constituted under the State Bank Of India Act and having its Asst. General Manager, State Bank Of India, Regional Administrative Office, RBO-2 (SAO), SURAT

Herein after called the Bank which expressions shall include its successors and assigns -----

-----of the one
part and _____ (name & address of
contractor) _____ hereinafter called the "Contractor" which
expression shall include the successors and assigns of the other part.

ANDWHEREAS for the said, **INTERIOR FURNISHING WORK for STATE BANK OF INDIA PARLE POINT BRANCH DIST: - SURAT** Terms & Conditions, Specifications and the Schedule of items quantities etc, have been signed by and on behalf of the parties hereto.

AND WHEREAS the Contractor has agreed to execute upon, subject to the conditions set forth herein and Schedule of Items and quantities, General & Special Conditions of Contract, specifications etc contained in the tendered documents including all correspondences exchanged by or between the parties from the submission of tender till the award of work, both letters inclusive, (all of which are collectively hereinafter referred to as "the said conditions" , details of which are described in the schedule attached hereto, the works shown upon the said drawings and/or described in the said specification and included in the schedule of items and quantities at the respective rates therein set forth amounting to the sum as therein arrived at or such other sum shall become payable there under arrived at or such other sum as shall become payable there under (hereinafter referred to as "the said contract amount")

NOW IT IS HEREBY AGREED AS FOLLOWS

1. In consideration of the said contract amount to be paid at the time and in the manner set forth in the said conditions, the contractor shall upon and subject to the said conditions execute and complete the work shown in the said drawings and described in the said specifications and the schedule of items and quantities, as per the terms and conditions contained in the said conditions
2. The Bank shall pay the Contractor the said contract amount, or such other sum as shall become payable, at the time and in the manner specified in the said conditions.
3. The Architects in the said condition shall mean the said **M/s. Vishal Parekh**, architects, In the event of their ceasing to be the Architects for the

purpose of this contract for whatever reason, such other person or persons as shall be nominated for that purpose by the Bank, provided always that no person subsequently appointed as Architects under this contract shall be entitled to disregard or over rule any previous decisions or approvals or directions given or expressed in writing by the Architects for the time being.

4. The said general condition, Special condition, technical drawings, Notice Inviting Tender, specifications, Guarantee, Instruction to Tenderers Price Bid (Schedule of Quantities), Correspondences, Letter of Acceptance, Agreements and Appendices there to, contained in the tendered documents/said conditions shall be read and considered as forming part of this Agreement, and the parties hereto shall respectively abide by, submit themselves to the said conditions and perform the agreements on their part respectively in the said conditions contained therein.

The plans, agreements and documents mentioned herein shall form the basis of this contract. This contract is neither a fixed Lump Sum contract but is a contract to carry out the work in respect of **INTERIOR FURNISHING WORK for STATE BANK OF INDIA AT PARLEPOINT BRANCH, Surat DIST:- SURAT.**

5. As per the scope described and to be paid for according to actual measured quantities at the rates contained in the Schedule of Rates and / or negotiated rates and Probable quantities or as provided in the said condition.
6. The Bank reserves to itself the rights of altering the specifications and nature of the work by adding to or omitting any items of work or having portions of the same carried out without prejudice to this contract.
7. (a) The Contractors represent that they have experience and competent staff which will enable them to ensure proper quality check on the materials, whether brought by the contractors or supplied by the Bank to the contractors, and which will ensure that the contractor will carry out proper tests as required by the specifications and will supervise the day to day working and execution of the contract work.

(b) If the contractors have any doubt about the quality of the materials or any difficulty in supervision of the day to day work it shall be duty of the contractors to report the matter in writing forthwith to the Bank and for the time being suspend that portion of the work about which difficulty is experienced, and the contractors will abide by the directions given by the Bank.

(c)) The contractors are aware that the Bank will not give day-to-day supervision but will periodically supervise and the contractor has to perform their obligations under the instructions given to him periodically and under sub clauses (a) and (b) above.

(d) The contractors covenant and warrant that completed items of work as well as the entire work on completion will be in conformity with the specifications and the terms and conditions contained in the said conditions and will be of contract quality and description.

8. Time shall be considered as the essence of this contract and the contractor hereby agrees to commence the work on the day on which he is instructed to take possession of the site or from the fourteenth day after the day of issue of formal Work Order as provided for in the said conditions whichever is later and to complete the entire work within 45 days subject nevertheless to the provisions for the extension of time.

1. All payments by the Bank under this contract will be made only at **Parlepoint Branch, Surat Dist: - Surat.**

2. Any dispute arising under this Agreement shall be referred to arbitration in accordance with the stipulation laid down in the general conditions of contract.

3. The contents of this agreement have been read by the contractor and fully understood by the contractor.

IN WITNESS WHEREOF the Bank and the Contractor have set their respective hands to these Presents and two duplicates hereof the day and year first herein above written (If the Contractor is a Partnership Firm or an Individual).

IN WITNESS WHEREOF the Bank has set its hands to these presents through its duly authorized official and the contractor has caused its common seal to be affixed hereunto and the said duplicates have /has caused these presents and the said two duplicates hereof to be executed on its behalf, the day and year first herein above written (If contractor is a Company).

Signature clause:

SIGNED AND DELIVERED

By the hand of Shri -----Asst. General Manager, of State Bank Of India (Name and Designation)

In presence of _____

1. _____

Address _____

2. _____

Address _____

(Witness)

SIGNED AND DELIVERED by _____ (If the Contractor is a Partnership Firm or an individual , should be signed by all partners or by duly authorized person on behalf of all partners)

(1) _____

Address _____

(2) _____

Address _____

(Witness)

THE COMMON SEAL OF _____ was hereinto affixed pursuant to the resolution By Board of Directors at the Meeting held on _____ (If the Contractor signs under its common seal, the Signature Clause should tally with the sealing clause in the Articles of Association)

SIGNED AND DELIVERED by

(1) _____

(2) _____

1) _____

Address _____

(2) _____

Address _____

(Witness)

SIGNED AND DELIVERED by _____ (If the Contractor has signed by the hand of Power of Attorney, whether a Company or Individual)

(1) _____

Address _____

(2) _____

Address _____

(Witness)

SECTION – 1 INSTRUCTIONS TO THE TENDERERS

1.0 Scope of work

Sealed Tenders followed by e-reverse auction are invited by **M/s. Vishal Parekh, Architects, SURAT**, for and behalf of SBI / SBIIMSPL for the Proposed **FURNISHING WORKS FOR PARLEPOINT BRANCH AT PARLEPOINT, SURAT DIST. SURAT**

1.1 Site and its location

The proposed work is to be carried out at PARLEPOINT Branch at PARLEPOINT, SURAT Distt --- SURAT

2.0 Tender documents

2.1 The work has to be carried out strictly according to the conditions stipulated in the tender consisting of the following documents and the most workmen like manner.

Instructions to tenderers
General conditions of Contract
Special conditions of Contract
Additional Specifications
Drawings
Priced bid A

2.2 The above documents shall be taken as complementary and mutually explanatory of one another but in case of ambiguities or discrepancies, shall take precedence in the order given below;

- a) Price Bid
- b) Additional Specifications
- c) Technical specifications
- d) Drawings
- e) Special conditions of contract
- f) General conditions of contract
- g) Instructions to Tenderers

2.3 Complete set of tender documents including relative drawings can be downloaded from the website www.sbi.co.in

2.4 The tender documents are not transferable.

3.1 Site Visit:

Ar.Vishal Parekh

Sign and Seal of Contractor

3.2 The tenderer must obtain himself on his own responsibility and his own expenses all information and data that may be required for the purpose of filling this tender document and enter into a contract for the satisfactory performance of the work. The tenderer is requested satisfy himself regarding the availability of water, power, transport and communication facilities, the character quality and quantity of the materials, labour, the law and order situation, climatic conditions local authorities requirement, traffic regulations etc; The tenderer will be fully responsible for considering the financial effect of any or all the factors while submitting his tender.

4.1 Earnest Money:

4.2 The tenderers are requested to submit the Earnest Money of **Rs.7,000 (Rupees Seven Thousand only) only by means of Demand Draft/Pay Order**(Valid for a period of 90 Days from the last date of submission of the tender) from any scheduled Nationalized Bank drawn **in favour of SBI Infra Management Solutions Pvt. Ltd. and payable at Ahmedabad.**

4.3 EMD in any other form other than as specified above will not be accepted. Tender not accompanied by the EMD in accordance with clause 4.1 above shall be rejected.

4.4 No interest will be paid on the EMD.

4.5 EMD of unsuccessful tenderer will be refunded within 30 days of award of Contract.

4.6 EMD of successful tenderer will be retained as a part of security deposit.

5.1 Initial Security Deposit:

The successful tenderer will have to submit a sum equivalent to 2% of accepted tender value less EMD by means of DD drawn in favour of SBIIMS Payable at SURAT within a period of 7 days of acceptance of tender.

5.2 Security Deposit:

Total security deposit shall be 5% of contract value. Out of this 2% of contract value is in the form of Initial Security Deposit (ISD) which includes the EMD. Balance 3% shall be deducted from the running account bill of the work at the rate of 10% of the respective running account bill i.e., deduction from each running bill account will be @ 10% till Total Security Deposit (TSD) including ISD reaches to 5% of contract value. The 50% of the Total Security Deposit shall be paid to the contract on the basis of architect's certifying the virtual completion. The balance 50% would be paid to the contractors after the defects liability period as specified in the contract

5.3 Signing of contract Documents:

The successful tenderer shall be bound to implement the contract by signing an agreement and conditions of contract attached herewith within 15 days from the receipt

of intimation of acceptance of the tender by the Bank. However, the written acceptance of the tenders by the Bank will constitute a binding agreement between the Bank and successful tenderer whether such formal agreement is subsequently entered in to or not.

6.0 Completion Period:

Time is essence of the contract. The work should be completed in all respect accordance with the terms of contract within a period of **30 days** from the date of award of work.

7.0 Validity of tender:

Tenders shall remain valid and open for acceptance for a period of 180 days from the date of e-reverse auction. If the tenderer withdraws his/her offer during the value period or makes modifications in his/her original offer which are not acceptable to Bank without prejudice to any other right or remedy the Bank shall be at liberty forfeit the EMD.

8.0 Liquidated Damages:

The liquidated damages shall be 0.50% per week subject to a maximum of 5% of contract value.

9.0 Rate and prices:

9.0.1 In case of item rate tender:

The tenderers shall quote their rates for individual items both in words and figure. In case of discrepancy between the rate quoted in words and figures, the unit rate quantity in words will prevail. If no rate is quoted for a particular item the contractor shall not be paid for that item when it is executed. The amount of each item shall be calculated and the requisite total is given. In case of discrepancy between the unit rate and the total amount calculated from multiplication of unit rate and the quantity the unit rate quoted will govern and the amount will be corrected.

The tenderers need not quote their rates for which no quantities have been given. In case the tenderers quote their rates for such items those rates will be ignored and will not be considered during execution.

The tenderers should not change the units as specified in the tender. If any unit is changed the tenders would be evaluated as per the original unit and the contractor would be paid accordingly.

The tenderer should not change or modify or delete the description of the item. If any discrepancy is observed he should immediately bring to the knowledge of the Architect/SBIIMS

Each page of the BOQ shall be signed by the authorized person and cutting or over writing shall be duly attested by him.

Each page shall be totaled and the grand total shall be given.

The rate quoted shall be firm and shall include all costs, allowances, materials, labours, taxes etc. except G.S.T, which shall be payable / reimbursed at actual

The SBIIMS reserve their rights to accept any tenders, either in whole or in part or may entrust the work in phases or may drop the part scope of work at any stage of the project within its sole discretion without assigning any reason(s) for doing so and no claim / correspondence shall be entertained in this regard.

SIGNATURE OF THE CONTRACTOR WITH SEAL

GENERAL CONDITIONS OF CONTRACT

1.0 Definitions:-

“Contract means the documents forming the tender and the acceptance thereof and the formal agreement executed between SBI (client) and the contractor, together with the documents referred there in including these conditions, the specifications, designs, drawings and instructions issued from time to time by the Architects / Bank and all these documents taken together shall be deemed to form one contract and shall be complementary to one another.

In the contract the following expressions shall, unless the context otherwise requires, have the meaning hereby respectively assigned to them.

1.0.1 ‘SBIIMS’ shall mean SBI Infra Management Solutions Pvt. Ltd.(Project Management Services Provider-PMS) having its Circle Office at Third Floor, SBI, LHO, Bhadra, Laldarwaja, Ahmedabad-380001 and includes the client’s representatives, successors and assigns.

1.0.2 ‘Architects/ Consultants’ shall mean **M/s. Vishal Parekh**, Surat

1.0.3 ‘Site Engineer’ shall mean an Engineer appointed by the SBIIMS at site as their representative for day-to-day supervision of work and to give instructions to the contractors.

1.0.4 ‘The Contractor’ shall mean the individual or firm or company whether incorporate not, undertaking the works and shall include legal personal representative of individual or the composing the firm or company and the permitted assignees of individual or firms of company. The expression ‘works’ or ‘work’ shall mean the permanent or temporary work description in the “Scope of work” and/or to be executed in accordance with the contract includes materials, apparatus, equipment, temporary supports, fittings and things of kinds to be provided, the obligations of the contractor hereunder and work to be done by the contractor under the contract.

1.0.5 ‘Engineer’ shall mean the representative of the Architect/consultant.

1.0.6 ‘Drawings’ shall mean the drawings prepared by the Architects and issued by the Engineer and refer red to in the specifications and any modifications of such drawings as may be issued by the Engineer from time to time Contract value shall mean value of the entire work as stipulated in the letter of acceptance of tender subject such additions there to or deductions there from as may be made under the provide herein after contained.

1.0.7 Specifications’ shall mean the specifications referred to in the tender and modifications thereof as may time to time be furnished or approved by the Architect/Consultant.

1.0.8 “Month” means calendar month.

1.0.9 “Week” means seven consecutive days.

1.0.10 “Day” means a calendar day beginning and ending at 00 Hrs and 24 Hrs respectively.

1.1.11 "SBIIMS's Engineer" shall mean The Civil/Electrical Engineer in-charge of the Project, as nominated by the Circle Head and Vice President, SBIIMS, Ahmedabad

1.1.12 The following shall constitute the Joint Project Committee (herein under referred to as JPC) for assessing and reviewing the progress of the work on the project and to issue instructions or directions from time to time for being observed and followed by the Architects Site Engineer / PMC and other consultants / contractors engaged in the execution of the project.

i) Vice President – Circle Head of SBIIMS ii) SBIIMS Engineer (Civil and Electrical) in-charge of the Project iii) Concerned partner of the Architects and their Resident Architect.... Member.

CLAUSE

1 a. Total Security Deposit

Total Security deposit comprise of Earnest Money Deposit, Initial security deposit and Retention Money

1 b. Earnest Money Deposit-

The tenderer shall furnish EMD of **Rs.7,000 (Rupees Seven Thousand only)** in the form of Demand draft or bankers cheque drawn in favour of **SBI Infra Management Solutions Pvt. Ltd. and payable at Ahmedabad** of any Scheduled Bank. No tender shall be considered unless the EMD is so deposited in the required form. No interest shall be paid on this EMD. The EMD of the unsuccessful tenderer shall be refunded soon after the decision to award the contract is taken without interest. The EMD shall stand absolutely forfeited if the tenderer revokes his tender at any time the period when he is required to keep his tender open acceptance by the SBIIMS or after it is accepted by the SBIIMS, the contractor fails to enter into a formal agreement or fails to pay the initial security deposit as stipulated or fails to commence the work within the stipulated time.

1 c. Initial Security Deposit (ISD)

The amount of ISD shall be 2% of accepted value of tender including the EMD in the form of DD/Fixed Deposit Receipt (FDR) drawn on any scheduled Bank and shall be deposited within 15 days from the date of acceptance of tender.

1 d. Retention Money:

Besides the SD as deposited by the contractor in the above said manner, the Retention money shall be deducted from the running account bill at the rate of 10% of the gross value of work done by the contractor and claimed in each bill provided the total security deposit i.e. ISD plus EMD plus Retention Money shall both together not exceed 5% of the contract value. The 50% of the total security deposit shall be refunded to the contractor without any interest on issue of Virtual Completion certificate by the Architect/consultant. The balance 50% of the total security deposit shall be refunded to the contractors without interest within fifteen days

after the end of defects liability period provided the contractor has satisfactorily attended to all defects in accordance with the conditions of contract including site clearance.

2.0 Language:

The language in which the contract documents shall be drawn shall be in English.

3.0 Errors, omissions and discrepancies:

In case of errors, omissions and/ or disagreement between written and scaled dimensions on the drawings or between the drawings and specifications etc., the following order shall apply.

- i) Between scaled and written dimension (or description) on a drawing, the latter shall be adopted.
- ii) Between the written or shown description or dimensions in the drawings and the corresponding one in the specification the former shall be taken as correct.
- iii) Between written description of the item in the specifications and descriptions in bills of quantities of the same item, the former shall be adopted:
 - a) In case of difference between rates written in figures and words, the rate in words shall prevail.
 - b) Between the duplicate / subsequent copies of the tender, the original tender shall be taken as correct.

4.0 Scope of Work:

The contractor shall carry-out complete and maintain the said work in every respect strictly accordance with this contract and with the directions of and to the satisfaction Bank to be communicated through the architect/consultant. The architect/consultant at the directions of the SBIIMS from time to time issue further drawings and / or write instructions, details directions and explanations which are here after collectively references to as Architect's / consultant's instructions in regard to the variation or modification of the design, quality or quantity of any work or the addition or omission or substitution work. Any discrepancy in the drawings or between BOQ and / or drawings and/or specifications. The removal from the site of any material brought thereon by the Contractor and any substitution of any other materials therefore the removal and/or re- execution of any work executed by him. The dismissal from the work of any person engaged the re upon.

5.0 i) Letter of Acceptance:

Within the validity period of the tender the SBIIMS shall issue a letter of acceptance directly or through the architect by registered post or otherwise depositing at the of the contractor as given in the tender to enter into a Contract for the execution of the work as per the terms of the tender. The letter of acceptance shall constitute a bind contract between the SBIIMS and the contractor.

ii) Contract Agreement:

On receipt of intimation of the acceptance of tender from the SBIIMS/Architect the successful tenderer shall be bound to implement the contract and within fifteen days there of shall sign an agreement in a non-judicial stamp paper of appropriate value.

6.0 Ownership of drawings:

All drawings, specifications and copies thereof furnished by the SBIIMS / SBI through its Architect / consultants are the properties of the SBIIMS They are not to be used on other work.

7.0 Detailed drawings and instructions:

The SBIIMS through its architects / consultants shall furnish with reasonable proper additional instructions by means of drawings or otherwise necessary for the execution of the work. All such drawings and instructions shall be consistent with contract documents, true developments thereof and reasonably inferable there.

The work shall be executed in conformity there with and the contractor prepare a detailed programme schedule indicating therein the date of start and completion of various activities on receipt of the work order and submit the same to the SBIIMS through the architect/consultant

Copies of agreement:

Two copies of agreement duly signed by both the parties with the drawings shall be handed over to the contractors.

8.0 Liquidated damages:

If the contractor fails to maintain the required progress in terms of clause 6.0 of "Instructions to tenderer" or to complete the work and clear the site including vacating their office on or before the contracted or extended date or completion, without justification in support of the cause of delay, he may be called upon without prejudice to any other right of remedy available under the law to the SBIIMS on account of such breach to pay a liquidated damages at the rate of 0.50% of the contract value which subject to a maximum of 5% of the contract value.

9.0 Materials, Appliances and Employees:

Unless or otherwise specified the contractor shall provide and pay for all materials, labour, water, power, tools, equipment transportation and any other facilities that are required for the satisfactory execution and completion of the work. Unless or otherwise specified all materials shall be new and both workmanship and materials shall be best quality. The contractor shall at all times enforce strict discipline and good order among his employees and shall not employ on the work any unfit person or anyone not skilled in the work assigned to him. Workman whose work or behavior is found to be unsatisfactory by the SBIIMS /Architect/ consultant he shall be removed from the site immediately.

10.0 Permits, Laws and Regulations:

Permits and licenses required for the execution of the work shall be obtained by the contractor at his own expenses. The contractor shall give notices and comply with the regulations, laws, and ordinances rules, applicable to the contract. If the contractor observes any discrepancy between the drawings and specifications, he shall promptly notify the SBIIMS in writing under intimation of the Architect/ Consultant. If the contractor performs any act, which is against the law, rules and regulations he shall meet all the costs arising the reform and shall indemnify the SBIIMS any legal actions arising there from.

11.0 Setting out Work:

The contractor shall set out the work and shall be responsible for the true and perfect setting out of the same and for the correctness of the positions, levels, dimensions, and alignment of all parts thereof and get it approved by the architect / consultant before proceeding with the work. If at any time any error in this respect shall appear during the progress of the works, irrespective of the fact that the layout had been approved by, the architect / consultant the contractor shall be responsible for the same ad shall his own expenses rectify such error, if so, required to satisfaction of the SBIIMS

12.0 Protection of works and property:

The contractor shall continuously maintain adequate protection. of all his work from damage and shall protect the SBI's properties from injury or loss arising in connection with contract. He shall make good any such damage, injury, loss, except due to causes beyond his control and due to his fault or negligence.

He shall take adequate care and steps for protection of the adjacent properties. The contractor shall take all precautions for safety and protections of his employees on the works and shall comply with all applicable provisions of Govt. and local bodies' safety laws and building codes to prevent accidents, or injuries to persons or property on about or adjacent to his place of work. The contractor shall take insurance covers as per clause at his own cost. The policy may be taken in joint names of the contractor and the SBIIMS and the original policy may be lodged with the SBIIMS

13.0 Inspection of work:

The SBIIMS / Architect / Consultant or their representatives shall at all reasonable times have free access to the work site and / or to the workshop, factories, or other places where materials are lying or from where they are obtained and the contractor shall give every facility to the SBIIMS/Architect/consultant and their representatives necessary for inspection and examination and test of the materials and workmanship. No person unless authorized by the SBIIMS/ Architect

/Consultant except the representative of Public authorities shall be allowed on the work at any time. The proposed work either during its construction stage or its completion can also be inspected by the Chief Technical Examiner's Organization a wing of Central Vigilance commission.

14.0 Assignment and subletting:

The whole of work included in the contract shall be executed the contractor and he shall not directly entrust and engage or indirectly transfer, assign or underlet the contract or any part or share there of or interest therein without the written consent of the SBIIMS through the Architect and no undertaking shall relieve the contractor from the responsibility of the contractor from active & superintendence of the work during its progress.

15.0 Quality of materials, workmanship & Test:

All materials and workmanship shall be best of the respective kinds described in the contract and in accordance with Architect/consultant instructions and shall be subject from time to time to such tests as the architect/consultant may direct at the place of manufacture or fabrication or on the site or an approved testing laboratory. The contractor shall provide such assistance, instruments, machinery, labor, and materials as are normally required for examining measuring sampling and testing any material or part of work before in corporation in the work for testing as may be selected and required by the architect/consultant.

ii) **Samples:**

All samples of adequate numbers, size, shades & pattern as per specifications shall be supplied by the contractor without any extra charges. If certain items proposed to be used are of such nature that samples cannot be presented or prepared at the site detailed literature / test certificate of the same shall be provided to the satisfaction of the Architect/consultant before submitting the sample/literature the contractor shall satisfy himself that the material / equipment for which he is submitting the sample / literature meet with the requirement of tender specification. Only when the samples are approved in writing by the architect/consultant the contractor shall proceed with the procurement and installation of the particular material / equipment. The approved samples shall be signed by the Architect / Consultant for identification and shall be kept on record at site office until the completion of the work for inspection / comparison at any time. The Architect/Consultant shall take reasonable time to approve the sample. Any delay that might occur in approving the samples for reasons of its not meeting the specifications or other discrepancies inadequacy in furnishing samples of best qualities from various manufacturers and such other aspects causing delay on the approval of the materials / equipment etc. shall be to the account of the contractor.

iii) **Cost of tests:**

The cost of making any test shall be borne by the contractor if such test is intended by or provided for in the specification or BOQ.

iv) **Costs of tests not provided for:**

If any test is ordered by the Architect/ Consultant which is either

a) If so intended by or provided for or (in the cases above mentioned) is not so particularized, or though so intended or provided for but ordered by the Architect / Consultant to be carried

out by an independent person at any place other than the site or the place of manufacture or fabrication of the materials tested or any Government / approved laboratory, then the cost of such test shall be borne by the contractor.

16.0 Obtaining information related to execution of work:

No claim by the contractor for additional payment shall be entertained which is consequent upon failure on his part to obtain correct information as to any matter affecting the execution of the work nor any misunderstanding or the obtaining incorrect information or the failure to obtain correct information relieve him from any risks or from the entire responsibility for the fulfillment of contract.

17.0 Contractor's superintendence:

The contractor shall give necessary personal superintendence during the execution the works and as long, thereafter, as the Architect/Consultant may consider necessary until the expiry of the defects liability period, stated hereto.

18.0 Quantities:

The bill of quantities (BOQ) unless or otherwise stated shall be deemed to have been prepared in accordance with the Indian Standard Method of Measurements and quantities. The rate quoted shall remain valid for variation of quantity against individual item to any extent. The entire amount paid under Clause 19, 20 hereof as well as amounts of prime cost and provision sums, if any, shall be excluded.

19.0 Works to be measured:

The Architect/Consultant may from time to time intimate to the contractor that he requires the work to be measured and the contractor shall forthwith attend or send a quantity representative to assist the Architect in taking such measurements and calculation and to furnish all particulars or to give all assistance required by any of them. Such measurements shall be taken in accordance with the Mode of measurements detail in the specifications. The representative of the Architect / Consultant shall take measurements with the contractor's representative and the measurements shall be entered in the measurement book. The contractor or his authorized representative shall sign all the pages of the measurement book in which the measurements have been recorded in token of his acceptance. All the corrections shall be duly attested by both representatives. No over writings shall be made in the M book should the contractor not attend or neglect or omit to depute his representative to take measurements the measurements recorded by the representative of the Architect/consultant shall be final. All authorized extra work, omissions and all variations made shall be included such measurement.

20.0 Variations:

No alteration, omission or variation ordered in writing by the Architect/consultant vitiates the contract. In case the SBIIMS/ Architect / Consultant thinks proper at any during the progress of works to make any alteration in, or additions to or omission from the works or any. Alteration in the kind or quality of the materials to be used therein, the Architect / Consultant

shall give notice thereof in writing to the contractor shall confirm in writing within seven days of giving such oral instructions the contract shall alter to, add to, or omit from as the case may be in accordance with such but the contractor shall not do any work extra to or make any alterations or additions to or omissions from the works or any deviation from any of the provisions of the contract, stipulations, specifications or contract drawings without previous consent in writing of the Architect/ Consultant and the value of such extras, alterations, additions or omissions shall in all cases be determined by the Architect / Consultant and the same shall be added to or deducted from the contract value, as the case maybe.

21.0 Valuation of Variations:

No claim for an extra shall be allowed unless it shall have been executed under the authority of the Architect / Consultant with the concurrence of the SBIIMS as herein mentioned. Any such extra is herein referred to as authorized extra and shall be made in accordance with the following provisions.

- (i) The net rates or prices in the contract shall determine the valuation of the extra work where such extra work is of similar character and executed under similar conditions as the work price herein.
- (ii) Rates for all items, wherever possible should be derived out of the rates given in the priced BOQ.

The net prices of the original tender shall determine the value of the items omitted, provided if omissions do not vary the conditions under which any remaining items of Works are carried out, otherwise the prices for the same shall be valued under sub- Clause 'c' hereunder.

Where the extra works are not of similar character and/or executed under similar conditions as aforesaid or where the omissions vary the conditions under which any remaining items or works are carried out, then the contractor shall within 7 days of the receipt of the letter of acceptance inform the Architect/ consultant of the rate which he intends to charge for such items of work, duly supported by analysis of the rate or rates claimed and the Architect/consultant shall fix such rate or prices as in the circumstances in his opinion are reasonable and proper, based on the market rate.

Where extra work cannot be properly measured or valued the contractor shall be allowed day work prices at the net rates stated in the tender, of the BOQ or, if not, so stated then in accordance with the local day work rates and wages for the district; provided that in either case, vouchers specifying the daily time (and if required by the Architect/Consultant) the workman's name and materials employed be delivered for verifications to the Architect /consultant at or before the end of the week following that in which the work has been executed.

It is further clarified that for all such authorized extra items where rates cannot be derived from the tender, the Contractor shall submit rates duly supported by rate analysis worked on the 'market rate basis for material, labour hire / running charges of equipment and wastages

etc. plus 15% towards establishment charges, contractor's overheads and profit. Such items shall, not be eligible for escalation.

22.0 Final measurement:

The measurement and valuation in respect of the contract shall be completed within two months of the virtual completion of the work.

23.0 Virtual Completion Certificate (VCC):

On successful completion of entire works covered by the contract to the full satisfaction of the SBIIMS, the contractor shall ensure that the following works have been completed the satisfaction of the SBIIMS:

Clear the site of all scaffolding, wiring, pipes, surplus materials, contractor's labour equipment and machinery.

Demolish, dismantle and remove the contractor's site office, temporary works, structure including labour sheds/camps and constructions and other items and things whatsoever brought upon or erected at the site or any land allotted to the contractor by the SBIIMS not incorporated in the permanent works.

Remove all rubbish, debris etc. from the site and the land allotted to the contractor by the SBIIMS and shall clear, level and dress, compact the site as required by the SBIIMS

Shall put the SBIIMS in undisputed custody and possession of the site and all land allot by the SBIIMS

Shall hand over the work in a peaceful manner to the SBIIMS

All defects / imperfections have been attended and rectified as pointed out by the Architects to the full satisfaction of SBIIMS

Upon the satisfactory fulfillment by the contractor as stated above, the contractor is entitled to apply to the Architect / consultant is satisfied of the completion of work. Relative to which the completion certificate has been sought, the Architect/ consultant shall within fourteen (14) days of the receipt of the application for completion certificate, issue a VCC in respect of the work for which the VCC has applied.

This issuance of a VCC shall not be without prejudice to the SBIIMS's rights and contractor liabilities under the contract including the contractor's liability for defects liability nor shall the issuance of VCC in respect of the works or work at any site be construction as a waiver of any right or claim of the SBIIMS against the contractor in respect of or work at the site and in respect of which the VCC has been issued.

24.0 Work by other agencies:

The SBIIMS / Architect / consultant reserves the rights to use premises and any portion the site for execution of any work not included in the scope of this contract which it may desire to have carried out by other persons simultaneously and the contractor shall not only allow but also extend reasonable facilities for the execution of such work. The contractor however shall not be required to provide any plant or material for the execution of such work except by special arrangement with the SBI. Such work shall be carried out in such manner as not to impede the progress of the works included in the contract.

25.0 Insurance of works:

Without limiting his obligations and responsibilities under the contract the contractor shall insure in the joint names of the SBIIMS And the contractor against all loss of damages from whatever cause arising other than the excepted risks, for which he is responsible under the terms of contract and in such a manner that the SBIIMS and contractor are covered for the period stipulated I clause of GCC and are also covered during the period of maintenance for loss or damage arising from a cause, occurring prior to the commencement of the period of maintenance and for any loss or damage occasioned by the contractor in the course of any operations carried out by him for the purpose of complying with his obligations under clause.

The Works for the time being executed to the estimated current Contract value thereof, or such additional sum as may be specified together with the materials for incorporation in the works at their replacement value.

The constructional plant and other things brought on to the site by the contractor to the replacement value of such constructional plant and other things.

Such insurance shall be effected with an insurer and in terms approved by the SBIIMS which approval shall not be unreasonably withheld and the contractor shall whenever required produce to the Architect / consultant the policy if insurance and the receipts for payment of the current premiums.

26.0 Damage to persons and property:

The contractor shall, except if and so far as the contract provides otherwise indemnify the SBI against all losses and claims in respect of injuries or damages to any person or material or physical damage to any property whatsoever which may arise out of or in consequence of the execution and maintenance of the works and against all claims proceedings, damages, costs, charges and expenses whatsoever in respect of or in relation thereto except any compensation of damages for or with respect to:

- a) The permanent use or occupation of land by or any part thereof.
- b) The right of SBIIMS to execute the works or any part thereof on, over, under, in or through any lands.
- c) Injuries or damages to persons or properties which are unavoidable result of the execution or maintenance of the works in accordance with the contract.

- d) Injuries or damage to persons or property resulting from any act or neglect of the SBIIMS their agents, employees or other contractors not being employed by the contractor or for or in respect of any claims, proceedings, damages, costs, charges and expenses in respect thereof or in relation thereto or where the injury or damage was contributed to by the contractor, his servants or agents such part of the compensation as may be just and equitable having regard to the extent of the responsibility of the SBIIMS, their employees, or agents or other employees, or agents or other contractors for the damage or injury.

27.0 Contractor to indemnify SBIIMS:

The contractor shall indemnify the SBIIMS against all claims, proceedings, damages, costs, charges and expenses in respect of the matters referred to in the provision sub-clause 26.0 of this clause.

28.0 Contractor's superintendence:

The contractor shall fully indemnify and keep indemnified the SBIIMS against any action, claim, or proceeding relating to infringement or use of any patent or design or any alleged patent or design rights and shall pay any royalties which may be payable in respect to any article or part thereof included in the contract. In the event of any claim made under or action brought against SBIIMS in respect of such matters as aforesaid the contractor shall be immediately notified thereof and the contractor shall be at liberty, at his own expenses to settle any dispute or to conduct any litigation that may arise there from, provided that the contractor shall not be liable to indemnify the SBIIMS if the infringement of the patent or design or any alleged patent or design right is the direct result of an order passed by the Architect / consultant in this behalf.

29.0 Third Party Insurance:

Before commencing the execution of the work the contractor but without limiting his obligations and responsibilities under clause 25.0 of GCC shall insure against his liability for any material or physical damage, loss, or injury which may occur to any property including that of SBIIMS, or to any person, including any employee of the SBIIMS, by or arising out of the execution of the works or in the carrying out of the contract, otherwise than due to the matters referred to in the provision to clause 25.0 thereof.

30.0 Minimum amount of Third Party Insurance:

Such insurance shall be affected with an insurer and in terms approved by the SBIIMS which approval shall not be reasonably withheld and for at least the amount stated below. The contractor shall, whenever required, produce to the Architect / consultant the policy or policies of insurance cover and receipts for payment of the current premiums.

The minimum insurance cover for physical property, injury, and death is Rs.5 Lakh per occurrence with the number of occurrences limited to four. After each occurrence contractor will pay additional premium necessary to make insurance valid for four occurrences always.

31.0 Accident or Injury to workman:

The SBIIMS Shall not be liable for or in respect to any damages or compensation payable at law in respect or in consequence of any accident or injury to any workmen or other person in the employment of the contractor or any sub-contractor, save and except an accident or injury resulting from any act or default of the SBIIMS or their agents, or employees. The contractor shall indemnify and keep indemnified SBIIMS against all such damages and compensation, save and except as aforesaid, and against all claims, proceedings, costs, charges and expenses whatsoever in respect thereof or in relation thereto.

32.0 Insurance against accidents etc. to workmen:

The contractor shall insure against such liability with an insurer approved by the SBIIMS During the whole of the time that any persons are employed by him on the works and shall, when required, produce to the architect / consultant such policy of insurance and receipt for payment of the current premium. Provided always that, in respect of any persons employed by any subcontractor the contractor's obligation to insured as aforesaid under this sub-clause shall be satisfied if the sub-contractor shall have insured against the liability in respect of such persons in such manner that SBIIMS is indemnified under the policy but the contractor shall require such sub-contractor to produce to the Architect /consultant when such policy of insurance and the receipt for the payment of the current premium.

33.0 Remedy on contractor's failure to insure:

If the contractor fails to effect and keep in force the insurance referred to above or any other insurance which he may be required to effect under the terms of contract, then and in any such case the SBIIMS may effect and keep in force any such insurance and pay such premium or premiums as may be necessary for that purpose and from time to time deduct the amount so paid by the SBIIMS as aforesaid from any amount due or which may become due to the contractor, or recover the same as debt from the contractor.

Without prejudice to the others rights of the SBIIMS against contractors. In respect of such default, the employer shall be entitled to deduct from any sums payable to the contractor the amount of any damages costs, charges, and other expenses paid by the SBIIMS And which are payable by the contractors under this clause. The contractor shall upon settlement by the Insurer of any claim made against the insurer pursuant to a policy taken under this clause, proceed with due diligence to rebuild or repair the works destroyed or damaged. In this event all the monies received from the Insurer in respect of such damage shall be paid to the contractor and the Contractor shall not be entitled to any further payment in respect of the expenditure incurred for rebuilding or repairing of the materials or goods destroyed or damaged.

34.0 Commencement of Works:

The date of commencement of the work will be reckoned from the date of award of letter by the SBIIMS

35.0 Time for completion:

Time is essence of the contract and shall be strictly observed by the contractor. The entire work shall be completed within a period of **30 days** from the date of commencement. If required in the contract or as directed by the Architect / consultant. The contractor shall complete certain portions of work before completion of the entire work. However, the completion date shall be reckoned as the date by which the whole work is completed as per the terms of the contract.

36.0 Extension of time:

If, in the opinion of the Architect/consultant, the work be delayed for reasons beyond the control of the contractor, the Architect/consultant may submit a recommendation to the SBIIMS to grant a fair and reasonable extension of time for completion of work as per the terms of contract. If the contractor needs an extension of time for the completion of work or if the completion of work is likely to be delayed for any reasons beyond the due date of completion as stipulated in the contract, the contractor shall apply to the SBIIMS Through the Architect' Consultant in writing at least 30 Days before the expiry of the scheduled time and while applying for extension of time he shall furnish the reason in detail and his justification if an', for the delays. The architect/consultant shall submit their recommendations to the SBIIMS in the prescribed format for granting extension of time. While granting extension of time the contractor shall be informed the period extended time which will qualify for levy of liquidated damages. For the balance period in excess of original stipulated period and duly sanctioned extension of time by the provision of liquidated damages as stated under clause 10.0 shall become applicable. Further the contract shall remain in force even for the period beyond the due date of completion irrespective whether the extension is granted or not.

37.0 Rate of progress:

Whole of the materials, plant and labour to be provided by the contractor and the mode, manner and speed of execution and maintenance of the works are to be of a kind and conducted in a manner to the satisfaction of the Architect/consultant should the rate of progress of the work or any part thereof be at any time be in the opinion the. Architect / consultant too Slow to ensure the completion of the whole of the work the prescribed time or extended time for completion the Architect/consultant shall the re upon take such steps as considered necessary by the Architect / consultant to expedite progress so as to complete the works by the prescribed time or extended time. Such communications from the Architect / consultant neither shall relieve. The contractor from fulfilling obligations under the contract nor he will be entitled to raise any claims arising out of such directions.

38.0 Work during nights and holidays:

Subject to any provision to the contrary contained in the contract no permanent work shall save as herein provided be carried on during the night or on holidays without the permission in writing of the Architect/consultant, save when the work is unavoidable or absolutely necessary for the saving of life or property or for the safety of the work in which case the contractor shall immediately advise the Architect / consultant. However the provisions of the clause shall not be applicable in the case of any work which becomes essential to carry by rotary or double shifts in order to achieve the progress and quality of the part of the works

being technically required / continued with the prior approval of the Architect / consultant at no extra cost to the SBIIMS.

All work at night after obtaining approval from competent authorities shall be carried out without unreasonable noise and disturbance.

39.0 No compensation or restrictions of work:

If at any time after acceptance of the tender SBIIMS shall decide to abandon or reduce the scope of work for any reason whatsoever and hence not required the whole or any part of the work to be carried out. The Architect / consultant shall give notice in writing that effect to the contractor and the contractor shall act accordingly in the matter. The contractor shall have no claim to any payment of compensation or otherwise what so ever on account of any profit or advantage which he might have derived from the execution of the Work fully but which he did not derive in consequence of the fore closure of the whole or part of the work.

Provided that the contractor shall be paid the charges on the cartage only of materials actually and bonafide brought to the site of the work by the contractor and rendered surplus as a result of the abandonment, curtailment of the work or any portion thereof and then taken back by the contractor, provided however that the Architect/Consultant shall have in such cases the option of taking over all or any such materials at their purchase price or a local current rate whichever is less.

In case of such stores having been issued from SBIIMS stores and returned by the contractor to stores, credit shall be given to him at the rates not exceeding those at which were originally issued to the contractor after taking into consideration and deduction for claims on account of any deterioration or damage while in the custody of the contractor and in this respect the decision of Architect / consultant shall be final.

40.0 Suspension of work:

The contractor shall, on receipt of the order in writing of the Architect / consultant (whose decision shall be final and binding on the contractor) suspend the progress of works or any part the offer such time and in such manner as Architect/consultant may consider necessary so as not to cause any damage or injury to the work already done or endanger the safety thereof for any of following reasons:

- a) On account any default on the part of the contractor, or
- b) For proper execution of the works or part thereof for reasons other than the default the contractor, or
- c) For safety of the works or part thereof.

The contractor shall, during such suspension, properly protect and secure the works the extent necessary and carry out the instructions given in that behalf by the Architect / consultant. i)If the suspension is ordered for reasons (b) and (c) in sub-para (i) above:

The contractor shall be entitled to an extension of time equal to the period of every such suspension. No compensation whatsoever shall be paid on this account.

41.0 Action when the whole security deposit is forfeited:

In any case in which under any clause or clauses of this contract, the Contractor shall have rendered himself liable to pay compensation amounting to the whole of his security deposit the Architect / consultant shall have the power to adopt any of the following course as they may deem best suited to the interest of the SBIIMS:

To rescind the contract (of which rescission notice in writing to the contractor by - Architect / consultant shall be conclusive evidence) and in which case the security, deposit of the contractor shall be forfeited and be absolutely at the disposal of SBIIMS.

To employ labour paid by the SBIIMS and to supply materials to carry out the work, or part of the work, debiting the contractor with the cost of the labour and materials cost of such labour and materials as worked out by the Architect / consultant shall final and conclusive against the contractor) and crediting him with the value of the work done, in all respects in the same manner and at the same manner and at the same rates as if it had been carried out by the contractor under the terms of this contract certificate of architect /consultant as to the value of work done shall be final conclusive against the contractor.

To measure up the work of the contractor, and to take such part thereof as shall un-executed, out of his hands, and to give it to another contractor to complete in which case any expenses which may be incurred in excess of the sum which would have been paid to the original contractor, if the whole work had been executed by him (The amount of which excess the certificates in writing of the Architects / consultant shall final and conclusive) shall be borne by original contractor and may be deducted any money due to him by SBIIMS under the contract or otherwise, or from his security deposit or the proceeds of sale thereof, or sufficient part thereof.

In the event of any of above courses being adopted by the SBIIMS the contractor shall have no claim to compensation for any loss sustained by him by reasons of his having purchased or procured any material or entered into any engagements or make any advances on account of, or with a view to the execution of the work or the performance of the contract and incase the contract shall be rescind under the provision aforesaid, the contractor shall not be entitled to recover or to be paid any sum or any work thereto for actually performed under this contract, unless, and until the Architect / consultant will have certified in writing the performance of such work and the value payable in respect thereof, and he shall only been titled to be paid the value so certified.

42.0 Owner's right to terminate the contract:

If the contractor being an individual or a firm commit any 'Act of insolvency' or shall be adjusted an insolvent or being an incorporated company shall have an order for compulsory winding up voluntarily or subject to the supervision of Govt. and of the Official Assignee of the

liquidator in such acts of insolvency or winding up shall be unable within seven days after notice to him to do so, to show to the reasonable satisfaction of the Architect / Consultant that he is able to carry out and fulfill the contract, and to dye security therefore if so required by the Architect /Consultant.

Or if the contractor (whether an individual firm or incorporated Company) shall suffer execution to be issued or shall suffer any payment under this contract to be attached by or on behalf of any of the creditors of the contractor.

Or shall assign or sublet this contract without the consent in writing of the SBIIMS through the Architect/Consultant or shall charge or encumber this contract or any payment due to which may become due to the contractor there under:

Has abandoned the contract; or

has failed to commence the works, or has without any lawful excuse under these conditions suspended the progress of the works for 14 days after receiving from the SBIIMS through the Architect / consultant written notice to proceed, or

has failed to proceed with the works with such diligence and failed to make such due progress as would enable the works to be completed within the time agreed upon, or has failed to remove the materials from the site or to pull down and replace work within seven days after written notice from the SBIIMS through the Architect / Consultant that the said materials were condemned and rejected by the Architect/ consultant under these conditions; or has neglected or failed persistently to observe and perform all or any of the acts matters or things by this contract to be observed and performed by the contactor for seven days after written notice shall have been given to the contractor to observe or perform the same or has to the detriment of good workmanship or in defiance of the SBIIMS or Architect's / consultant's instructions to the contrary subject any part of the contract. Then and in any of said cases the SBIIMS and or the Architect / consultant, may not withstanding any previous waiver, after giving seven days' notice in writing to the contractor, determine the contract, but without thereby affecting the powers of the SBIIMS or the Architect/consultant or the obligation and liabilities of the contractor the whole of which shall continue in force as fully as if the contract had not been determined and as if the works subsequently had been executed by or on behalf of the contractor. And, further the SBIIMS through the Architect / consultant their agents or employees may enter upon and take possession of the work and all plants, took scaffoldings, materials, sheds, machineries lying upon the premises or on the adjoining lands or roads use the same by means of their own employees or workmen in carrying on and completing the work or by engaging any other contractors or persons to the work and the contractor shall not in any was interrupt or do any act, matter or thing to prevent or hinder such other contractor or other persons employed for complement and finishing or using the materials and plant for the works.

When the works shall be completed or as soon thereafter as convenient the SBIIMS Or architect/consultant shall give a notice in writing to the contractor to remove his surplus materials and plants and should the contractor fail to do so within 14 days after receive thereof by him the SBIIMS sell the same by publication, and after due publication, and shall, adjust the amount realized by such auction. The contractor shall have no right to question any of the act of the SBIIMS incidental to the sale of the materials etc.

43.0 Certificate of payment:

The contractor shall be entitled under the certificates to be issued by the Architect / consultant to the contractor within 10 working days from the date of certificate to payment from SBIIMS From time to time SBIIMS shall recover the statutory recovering other dues including the retention amount from the certificate of payment. Provided always that the issue of any certificate by the Architect / consultant during progress of works or completion shall not have effect as certificate of satisfaction relieve the contractor from his liability under clause.

The Architect / consultant shall have power to withhold the certificate if the work or in part thereof is not carried out to their satisfaction. The Architect/consultant may by any certificate make any corrections required previous certificate.

The SBIIMS shall modify the certificate of payment as issued by the architect/ consultant from time to time while making the payment

The contractor shall submit interim bills only after taking actual measurements and properly recorded in the Measurement books.

No interim payment should be made only **full & final payment will be paid.**

The final bill may be submitted by contractor within a period of one month from the date of virtual completion and Architect / consultant shall issue the certificate of payment within a period of two months. The SBIIMS Shall pay the amount within a period of three months from the date of issue of certificate provided there is no dispute in respect of rates and quantities.

The contractor shall submit the interim bills in the prescribed format with all details.

44.0

A. Settlement of Disputes and Arbitration:

Except where otherwise provided in the contract all questions and disputes to the meaning of the specifications, design, drawings and instructions herein before mentioned and as to the quality of workmanship or materials used on the work or as to any other question , claim, right, matter or thing whatsoever in any way arising out of or relating to the contract, designs, drawings specifications, estimates, instructions orders or these conditions or otherwise concerning the work or the execution or failure to execute the same whether arising during the progress of the work or after the cancellation, termination, completion or abandonment thereof shall be dealt with as mentioned hereinafter:

If the contractor considers that he is entitled to any extra payment or compensation in respect of the works over and above the amounts admitted as payable by the Architect or in case the

contractor wants to dispute the validity of any deductions or recoveries made or proposed to be made from the contractor raise any dispute, the contractor shall forthwith give notice in writing of his claim, or dispute to The Senior Vice President, SBIIMS, Head Office, Mumbai and endorse a copy of the same to the Architect, within 30 days from the date of disallowance thereof or the date of deduction or recovery. The said notice shall give full particulars of the claim, grounds on which it is based and detailed calculations of the amount claimed and the contractor shall not be entitled to raise any claim nor shall the SBIIMS be in any way liable in respect of any claim by the contractor unless notice of such claim shall have been given by the contractor to the Senior Vice President, SBIIMS, Head Office, Mumbai in the manner and within the time as aforesaid. The Contractor shall be deemed to have waived and extinguished all his rights in respect of any claim not notified to the Senior Vice President, Head Office, Mumbai in writing in the manner and within the time aforesaid.

B. Settlement of Disputes and Arbitration:

The Senior Vice President, Head Office, Mumbai shall give his decision in writing on the claims notified by the receipt of the contractor may within 30 days of the receipt of the decision of the

Sr. V.P., Head Office / Submit his claims to the conciliating authority namely the M.D. & C.E.O., SBIIMSPL, Head Office, Mumbai for conciliation along with all details and copies of correspondence exchanged between him and the SBIIMS

If the conciliation proceedings are terminated without settlement of the disputes, the contractor shall, within a period of 30 days of termination thereof shall give a notice to the concerned M.D. & C.E.O. of the SBIIMS for appointment of an arbitrator to adjudicate the notified claims falling which the claims of the contractor shall be deemed to have been considered absolutely barred and waived.

Except where the decision has become final, binding and conclusive in terms of the contract, all disputes or differences arising out of the notified claims of the contractor as aforesaid and all claims of the SBIIMS shall be referred for adjudication through arbitration by the Sole Arbitrator appointed by the M.D. & C.E.O. and who will be of Deputy General Manager rank. It will also be no objection to any such appointment that the Arbitrator so appointed is a SBIIMS, Officer and that he had to deal with the matters to which the Contract relates in the course of his duties as SBIIMS, Officer. If the arbitrator so appointed is unable or unwilling to act or resigns his appointment or vacates his office due to any reason whatsoever another sole arbitrator shall be appointed in the manner aforesaid by the said M.D. & C.E.O. of the SBIIMS Such person shall be entitled to proceed with the reference from the stage at which it was let by his predecessor.

It is a term of this contract that the party invoking arbitration shall give a list of disputes with amounts claimed in respect of each dispute along with the notice for appointment of arbitrator.

It is also a term of this contract that no person other than a person appointed by such Chief General Manager as aforesaid should act as arbitrator. The conciliation and arbitration shall be conducted in accordance with the provisions of the Arbitration & Conciliation Act 1996 or any or any accordance modification or reenactment thereof and the rules made there under.

It is also a term of the contract that if any fees are payable to the Arbitrator these shall be paid equally by both the parties. However, no fees will be payable to the arbitrator if he is a SBIIMS Officer.

It is also a term of the contract that the Arbitrator shall be deemed to have entered on the reference on the date he issues notice to both the parties calling them to submit their statement of claims and counter statement of claims. The venue of the arbitration shall be such place as may be fixed by the arbitrator in his sole discretion. The fees, if any of the arbitrators shall, if required to be paid before the award is made and published, be paid half and half by each of the parties. The Cost of the reference and of the award (including the fees, if any of the arbitrator) shall be in the discretion of the arbitrator who may direct to any by whom and in what manner, such costs or any part thereof, shall be paid and fix or settle the amount of costs to be so paid.

45.0 Water supply:

The contractor shall make his own arrangements for water required for the work and nothing extra will be paid for the same. This will be subject to the following condition.

- i) That the water used by the contractor shall be fit for construction purposes to the satisfaction of the Architect /consultant's.
- ii) The contractor shall make alternative arrangements for the supply of water if the arrangement made by the contractor for procurement of water in the opinion of the Architect / consultant is unsatisfactory.
- iii) In case contractor is permitted to use Bank's source of water supply provided at one point, the SBIIMS will recover amount from the final bill of contractor as per clause **51.0** of this document.
- iv) The contractor shall construct temporary well / tube well in SBIIMS land for taking water for construction purposes only after obtaining permission in writing from the SBIIMS The contractor has to make his own arrangements for drawing and distributing the water at his own cost. He has to make necessary arrangements. To avoid any accidents or damages caused due to construction and subsequent maintenance of the wells. He has to obtain necessary approvals from local authorities, if required, at his own cost. He shall restore the ground to its original condition after wells are dismantled on completion of work or hand over the well to the SBIIMS without any compensation as directed by the architect /consultant.

46.0 Power supply:

The contractor shall make his own arrangements for power and supply / distribution system for driving plant or machinery for the work and for lighting purpose at his own cost, the cost of running and maintenance of the plants are to be included in his tender prices, He shall pay all fees and charges required, by the power supply and include the same in his tendered rates and hold the owner free from all such costs. He has to obtain necessary approval from the appropriate authorities, if required.

In case contractor is permitted to use Bank's source of power supply provided at one point, the SBIIMS will recover amount from the final bill of contractor as per clause **51.0** of this document.

47.0 Treasure trove etc.

Any treasure trove, coin or object antique which may be found on the site shall be the property of SBIIMS and shall be handed over to the bank immediately.

48.0 Method of measurement:

Unless otherwise mentioned in the schedule of quantities or in mode of measurement, the measurement will be on the net quantities or work produced in accordance with up to date rules laid down by the Bureau of Indian Standards. In the event any dispute/ disagreement the decision of the Architect / consultant shall be final and binding on the corrector.

49.0 Maintenance of registers:

The contractor shall maintain the following registers as per the enclosed perform at site of work and should produce the same for inspection of SBIIMS /Architect / consultant whenever desired by them. The contractor shall also maintain the records / registers as required by the local authorities / Govt. from time to time.

- i) Register for secured advance ii)
- Register for hindrance to work iii)
- Register for running account bill iv)
- Register for labour

50.0 Force Majeure:

Neither contractor nor SBIIMS shall be considered in default in performance of the obligations if such performance is prevented or delayed by events such as but not war, hostilities revolution, riots, civil commotion, strikes, lockout, conflagrations, epidemics, accidents, fire, storms, floods, droughts, earthquakes or ordinances or any act of or for any other cause beyond the reasonable control of the party affected or prevents or delayed. However, a notice is required to be given within 30 days from the happening of the event with complete details, to the other party to the contract, if it is not possible to serve a notice, within the shortest possible period without delay.

As soon as the cause of force majeure has been removed the party whose ability perform its obligations has been affected, shall notify the other of such cessation and the actual delay incurred in such affected activity adducing necessary evidence in support thereof.

From the date of occurrence of a case off or force majeure obligations of the party affected.

51.0 Water power and other facilities:

The rate quoted by the contractor shall include all expenses that are required for providing all the water required for the work and the contractor shall make his own arrangements for the supply of good quality water suitable for the construction and good quality drinking water for their workers If necessary the contractor has to sink a tube well / open well and bring water by means of tankers at his own cost for the purpose The SBIIMS will not be liable to pay any charges in connection with the above

The rate quoted in the tender shall include the expenses for obtaining and maintaining power connections and shall pay for the consumption charges

The contractors for other trades directly appointed by the SBIIMS shall be entitled to take power and water connections from the temporary water and power supply obtained by the contractor However, the concerned contractor shall make their own arrangements to draw the supply and pay directly the actual consumption charges at mutually agreed rates between them. All municipal charges for drainage and water connection for Construction purposes shall be borne by the contractor and charges payable for permanent connections, if any, shall be initially paid by the contractor and the SBIIMS will reimburse the amount on production of receipts.

The SBIIMS as well as the Architect / consultant shall give all possible assistance to the Contractor's to obtain the requisite Permission from the various authorities, but the responsibility for obtaining the same in time shall be of the contractor.

In case contractor is permitted to use Bank's source of water and power supply provided at one point, the SBIIMS will recover @ 0.50% of final bill amount for water and electricity (combined) from the bill of contractor.

52.0 Facilities for contractor's employees:

The contractor shall make his own arrangement for the housing and welfare of his staff and workmen including adequate drinking water facilities. The contractor shall also make the arrangements at his own cost for transport where necessary for his staff and workmen to and from site of work at his own cost.

53.0 Lighting of works:

The contractor shall at all times provide adequate and approved lighting as required for the proper execution and supervision and inspection of work.

54.0 Firefighting arrangements:

The contractor shall provide suitable arrangement for firefighting at his own cost. This purpose he shall provide requisite number of fire extinguishers and adequate number of buckets, some of which are to be always kept filled with sand and some with water these equipment shall be provided at suitable prominent and easily accessible place and shall be properly maintained. Any deficiency in the fire safety or unsafe conditions shall be corrected by the contractor at his own cost and, to the approval of the relevant authorities. The contractor make the following arrangements at his own cost but not limited the following:

- a) Proper handling, storage and disposal of combustible materials and waste.
- b) Work operations which can create fire hazards.
- c) Access for fire-fighting equipment.
- d) Type, number and location of containers for the removal of surplus materials and rubbish.
- e) Type, size, number and location of fire extinguishers or other fire fighting equipment.
- f) General housekeeping.

55.0 Site order book:

A site order book shall be maintained at site for the purpose of quick communication between the Architect / Consultant. Any communication relating to the work may be conveyed through records in the site order book. Such a communication from one party to the other shall be deemed to have been adequately served in terms of contract Each site order book shall have machine numbered pages in triplicate and shall carefully maintained and preserved by the contractor and shall be made available to the architect

/consultant as and when demanded- Any instruction which the architect/consultant may like to issue to the contractor or the contractor may like to bring to the architect / consultant two copies of such instructions shall be taken from the site order book and one copy will be handed over to the party against proper acknowledgment and the second copy will be retained for their record.

56.0 Temporary fencing/barricading:

The contractor shall provide and maintain a suitable temporary fencing/barricading and gates at his cost to adequately enclose all boundaries of the site for the protection of the public and for the proper execution and security of the work and in accordance with the requirement of the architect/consultant and regulations of local authorities. These shall be altered, relocated and adopted from time to time as necessary and removed on completion of the work.

57.0 Site meetings:

Site meetings will be held to review the progress and quality evaluation. The contractor shall depute a senior representative along with the site representative and other staff of approved sub-contractors and suppliers as required to the site meetings and ensure all follow up actions. Any additional review meetings shall be held if required by the architect/ consultant. -

58.0 Disposal of refuse:

The contractor shall cart away all debris, refuse etc. arising from the work from the site and deposit the same as directed by the architect / consultant at his own cost. It is the responsibility of the contractor to obtain from the local authorities concerned to the effect that all rubbish arising out of contractor's activities at the construction site or any other off-site activities borrow pits has been properly disposed off.

59.0 Contractor to verify site measurement:

The contractor shall check and verify all site measurements whenever requested other specialists contractors or other sub-contractors to enable them to prepare the own shop drawing and pass on the information with sufficient promptness as will in any way delay the works.

60.0 Displaying the name of the work:

The contractor shall put up a name board of suitable size as directed by the architect/ consultant indicating there in the name of the project and other details as given by the architect/consultant at his own cost and remove the same on completion of work.

61.0 As built drawings:

For the drawings issued to the contractor by the Architect / Consultant. The architect Consultant will issue two sets of drawings to the Contractor for the items for some changes have been made. From the approved drawings as instructed by the SBIIMS / Architect / Consultant. The contractor will make the changes made on these copies and return these copies to the architect / Consultant for their approval. In cases revision is required or the corrections are not properly marked the architect/Consultant will point out the discrepancies to the contractor. The contractor will have to incorporated these corrections and / or attend to discrepancies either on copies as directed by the architect / consultant and resubmit to him for approval. The architect / consultant will return one copy duly approved by him.

For the drawings prepared by the contractor:

The contractor will modify the drawing prepared by him wherever the changes made by the SBIIMS / architect / consultant. And submit two copies of such modified drawings to the architect/ consultant for approval. The architect / consultant will return one copy of the approved drawing to the contractor.

62.0 Approved make:

The contractor shall provide all materials from the list of approved makes at his own cost and also appoint the specialized agency for the waterproofing, anti-termites treatment, aluminum doors and windows and any other item as specified in the tender. The architect/consultant may approve any make / agency within the approved list as given in the tender after inspection of the sample/mockup.

63.0 Procurement of materials:

The contractor shall make his own arrangements to procure all the required materials for the work. All wastages and losses in weight shall be to the contractors account

64.0 Excise duty, taxes, levies etc.:

The contractor shall pay and be responsible for payment of all taxes, duties, levies, royalties, fees, cess or charges in respect of the works including but not limited to sales tax, tax on works contract excise duty, and Octroi, payable in respect of materials, equipment plant and other things required for the contract. All of the aforesaid taxes, duties, levies, fees and charges shall be to the contractor's account and the SBIIMS Shall not be required to pay any additional or extra amount on this account. Variation of taxes, duties, fees, levies etc. if any, till completion of work shall be deemed to be included in the quoted rates and no extra amount on this account. Variation of taxes, duties, fees, levies etc. if any, till completion of work shall be deemed to be included in the quoted rates and no extra claim on this account will in any case be entertained. If a new tax or duty or levy or cess or royalty or Octroi is imposed under as statutory law during the currency of contract the same shall be borne by the contractor. However, GST will be paid extra.

65.0 Acceptance of tender:

The SBIIMS shall have the right to reject any or all tenders without assigning any reason. They are not to bind to accept the lowest or any tender and the tenderer or tenderers shall have no right to question the acts of the SBIIMS However adequate transparency would be maintained by the SBIIMS

66.0 Photographs:

The Contractor shall at his own expense supply to the Architects with duplicate hard copies of large photographs not less than 25 cm. x 20 cm. (10" x 8") of the works, taken from two approved portions of each building, at intervals of not more than one months during the progress of the work or at every important stage of construction.

In addition to above, the contractor shall be bound to submit adequate no. of site photographs along with each Running Bill for the project clearing showing major progress of work measured and claimed therein failing which the Architect/ SBIIMS may consider returning the Bill to the contractor and no claim for delay on this account will be entertained.

67.0 Safety Codes:

1. First aid appliances including adequate supply of sterilized dressing and cotton wool shall be kept in a readily accessible place.
2. An injured person shall be taken to a public hospital without loss of time, in cases when the injury necessitates hospitalization.
3. Suitable and strong scaffolds should be provided for workmen for all works that cannot safely be done from the ground.

4. No portable single ladder shall be over 8 meters in length. The width between the side rails shall not be less than 30 cm. (clear) and the distance between two adjacent rungs shall not be more than 30 cm. When a ladder is used an extra labour shall be engaged for holding ladder.
5. The excavated material shall not be placed within 1.5 meters of the edge of the trench half of the depth of trench whichever is more. All trenches and excavations shall be provided with necessary fencing and lighting.
6. Every opening in the floor of a building or in a working platform be provided with suitable means to prevent the fall of persons or materials by providing suitable fencing or railing whose minimum height shall be one meter.
7. No floor, roof or other part of the structure shall be so overloaded with debris or material as to render it unsafe.
8. Workers employed on mixing and handling material such as asphalt, cement, mortar, concrete and lime shall be provided with protective footwear and rubber hand gloves.
- 9 Those engaged in welding works shall be provided with welders' protective eye shield and gloves.
10. (i) No paint containing lead or lead products shall be used except in the form of paste readymade paint.
(ii) Suitable face masks should be supplied for use by the workers when the paint applied in the form of spray or surface having lead paint dry rubbed and scrapped.
11. Overalls shall be supplied by the contractor to the painters and adequate facilities shall be provided to enable the working painters to wash during cessation of work.
- 12 Hoisting machines and tackle used in the works including their attachments anchor and supports shall be in perfect condition.
13. The ropes used in hoisting or lowering material or as a means of suspension shall be durable quality and adequate strength and free from defects.

APPENDIX HEREIN BEFORE REFERRED TO

1) Name of the organization Offering Contract: **The Asst. General Manager, State Bank of India, Regional Business Office-2, Ghod Dod Road, Near Panjra Pole, Surat – 395 001**

2) Consultants : **M/s Ar. Vishal Parekh**

3) Site Address : PARLEPOINT, SURAT DISTT.SURAT

4) Scope of Work: Proposed Furnishing works for PARLEPOINT Branch at PARLEPOINT

5) Name of the Contractor : -----

6) Address of the Contractor : -----

7) Period of Completion : 30 days from the date of
• Issue of work order.

8) Earnest Money Deposit : **Rs.7,000 (Rupees Seven Thousand only) by means of Demand Draft/Pay Order** (Valid for a period of 90 Days from the last date of submission of the tender) from any scheduled Nationalized Bank drawn **in favour of SBI Infra Management Solutions Pvt. Ltd. and payable at Ahmedabad.**

9) Retention Money : As per clause no.1d. of
general Conditions

10) Defects Liability Period : Twelve Months from the date of
Virtual Completion.

11) Insurance to be undertaken by the : 125% of Contract Value
Contractor at his cost (Contractor's all risk policy)

12) Liquidated damages : 0.5% of the Contract amount shown in the tender per week subject to max. 5% of the contract value or actual final bill value.

13) Value of Interim Bill (Min.) : No Interim payment will be paid

- 14) Date of Commencement : From the date of work order issued to the Contractor/ or the day on which the Contractor is instructed to take possession of the site whichever is earlier.
- 15) Period of Final Measurement :2 Months from the date of Virtual Completion.
- 16) Initial Security Deposit : 2% of the Accepted Value of the Tender.
- 17) Total Security Deposit : 5% of the final bill amount including ISD.
- 18) Refund of initial Security Deposit comprising of EMD and ISD. : 50% of the Security Deposit shall be refunded to the Contractor on completion of the work and balance refunded only after the Defect Liability Period is over.
- 19) Period for Honoring Certificate : One Month for R.A.Bills
- 20) The final bill will be submitted by the Contractor within one month of the date fixed for completion work and the Bill shall be Certified within 3 months from the date of receipt of final bill provided the bills are submitted with all pre-requisite documents/test reports etc. prescribed in the tender.

Signature of Tenderer.

Date:

LETTER OF DECLARATION

To,
The Asst. General Manager,
State Bank of India,
Regional Business Office-2,
Panjrapol,
Ghod Dod Road,
Surat– 395 001

Dear Sir,

PROPOSED FURNISHING WORKS FOR PARLEPOINT BRANCH AT PARLEPOINT DISTT. SURAT

Having examined the terms & conditions, drawings, specifications, design relating to the works specified in the memorandum hereinafter set out and having visited and examined the site of the works specified in the said memorandum and having acquired the requisite information relating thereto and affecting the quotation, I/We hereby offer to execute the works specified in the said memorandum within the time specified in the said memorandum on the item rate basis mentioned in the attached schedule and in accordance in all respect with the specifications, design, drawings and instructions in writing referred to in conditions of Tender, the articles of agreement, conditions of contract and with such conditions so far as they may be applicable.

MEMORANDUM

(a)	Description of work	Proposed Furnishing works at new premises at State Bank of India PARLEPOINT Branch
(b)	Earnest Money	Rs.7,000(Rupees Seven Thousand only) by means of Demand Draft / Pay Order (Valid for a period of 90 Days from the last date of submission of the tender) from any scheduled Nationalized Bank drawn in favour of SBI Infra Management Solutions Pvt. Ltd. and payable at Ahmedabad.
(c)	Time allowed for completion of work from the date of issue of work order.	30 days from the date of commencement as per tender.

Should this tender be accepted, I/we hereby agree to abide by and fulfill the terms and provisions of the said conditions of Contract annexed hereto so far as they may be applicable or in default thereof to forfeit and pay to SBIIMS, the amount mentioned in the said conditions.

I/we have deposited Demand Draft / Banker's Cheque / FDR for a sum of **Rs.7,000 (Rupees Seven Thousand only)** as Earnest money deposit with the SBI Infra Management Solutions Pvt. Ltd. Should I/we do fail to execute the contract when called upon to do so, I/we hereby agree that this sum shall be forfeited by me/us to SBI Infra Management Solutions Pvt. Ltd.

We understand that as per terms of this tender, the SBIIMS may consider accepting our tender in part or whole or may entrust the work of various buildings proposed (i.e. Institute Building, Staff Qtrs. And Director's Bungalow/Interior work) in phases. We, therefore, undertake that we shall not raise any claim/compensation in the eventuality of Bank deciding to drop any of the building/buildings from the scope of work of this tender at any stage during the contract period. Further, we also undertake to execute the work entrusted to us in phases on our approved rates and within the stipulated time limit without any extra claim for price escalation as provided for in Clause 9.0.1 "Instructions to Tenderers" of this tender.

We, hereby, also undertake that, we will not raise any claim for any escalation in the prices of any of the material during the currency of contract/execution/completion period.

Yours faithfully,

Signature of contractor With Seal

PROFORMA FOR RUNNING A/C BILL
TABLE - XIII

- i. Name of Contractor/ Agency :
- ii. Name of Work :
- iii. Sr. No. of this Bill:
- iv. No. & Date of previous Bill :
- v. Reference to Agreement No. :
- vi. Date of Written order to commence :
- vii. Date of Completion as per Agreement :

S. No	Item Description	Unit	Rate (Rs.)	As per Tender		Up to Previous R.A. Bill		Up to Date (Gross)		Present Bill		Remarks
				Qty	Amount (Rs.)	Qty	Amount (Rs.)	Qty	Amount (Rs.)	Qty	Amount (Rs.)	
1	2	3	4	5	6	7	8	9	10	11	12	13

Note:

1.	If part rate is allowed for any items, it should be indicated with reasons for allowing such a rate.	_____ _____ Net Value since previous bill
2.	If ad-hoc payment is made, it should be mentioned specifically.	

CERTIFICATE

The measurements on the basis of which the above entries for the Running Bill No. ---- --
----- were made have been taken jointly on ----- and are
recorded at pages ----- to ----- of measurement book
No.-----.

-----	-----	-----
Signature and date of Contractor	Signature and date of Architects Representative (Seal)	Signature and date of Site Engineer

The work recorded in the above-mentioned measurements has been done at the site
satisfactorily as per tender drawings, conditions and specifications.

-----	-----
Architect	Signature and date of Site Engineer

MEMORANDUM FOR PAYMENT

R/A BILL NO.

1.	Total value of work done since previous bill (A)	Rs.....
2.	Total amount of secured advance due since Previous Bill (B)	Rs.....
3.	Total amount due since Previous Bill (C) (A+B)	Rs.....
4.	PVA on account of declaration in price of Steel, Cement and other materials and labour as detailed in separate statements enclosed.	Rs.....
5.	Total amount due to the Contractor	Rs.....
	<u>OBJECTIONS:</u>	
i)	Secured Advance paid in the previous R/A	Rs.....
ii)	Retention money on value of works as per accepted tenders up to date amount Rs.	Rs.....
	Less already recovered	Rs.....
	Balance to be recovered	Rs.....
iii)	Mobilization Advance, if any	Rs.....
(a)	Outstanding amount (principal + interest) as on date	Rs.....
(b)	To be recovered in this bill	Rs.....
iii.	Any other Departmental materials cost to be recovered as per contract, if any	Rs.....
iv.	Any other Departmental service charges to be recovered if any, as per contract (water, power etc.) enclose statement.	Rs.....

The bill amount to Rs. ----- (both figures and words) has been scrutinized by us after due checking of the measurements of work as required and is recommended for payment.

Date:-----

Signature of Architect with Seal

The bill amount to Rs.-----certified by Consultants has been scrutinized by me after due test checking of measurements of works as required and is recommended for payment for an amount of Rs.....

Date : -----

Signature of Banks/ SBIIMS Engineer

<u>STATUTORY DEDUCTION:</u>		
i)	Total Amount due (E)	Rs. -----
ii)	Less I.T. Payable	Rs. -----
iii)	Less S.T. Payable	Rs. -----
	Net Payable	Rs. -----

This figures given in the Memorandum for payable has been verified and bill passed for payment ----- (in words and figures)

Date:-----

Signature of the Circle Head & VP

TECHNICAL SPECIFICATION

SPECIFICATIONS OF MATERIALS TO BE USED

General:

This specifications are for the work to be executed items to be supplied and materials to be used in the works as shown and defined on the drawings and described here in all under the supervision and to the satisfaction of the architect / employer.

The workmanship is to be the best available and to a high standard. Use must be made of specialist tradesmen in all aspects of the works, and allowance must be made in the rates for doing so.

The materials and items to be provided by the contractor shall be the best of their respective kinds, approved by the architect in accordance with any samples, which may be submitted for approval, and generally in accordance with the specification. Where materials or products are specified in this specification and/ or bill of quantities by the name of the manufacture or the brand trade name or catalogue references the contractor will be required to obtain the approval of the architect/ employer before using a material or product other than the specified. The contractor shall produce all invoices, vouchers or receipted accounts for any materials of called upon to do so by the architect.

Sample of all material are to be submitted to the architect for his approval before the contractor orders or delivers in bulk to the site. Also, the contractor will be required to submit specimen finishes to colors, fabrics etc. For the approval of the architect before proceeding with the works. Should it be necessary to prepare shop drawings, then four copies of such drawings shall be submitted for the approval of the architect who will retain to copies, all at the contractors expenses.

Materials

The materials shall be of the best-approved quality obtainable and shall comply with the respective Indian standard specification.

If directed, materials shall be tested in any approved testing laboratory and the test certificates in original shall be submitted to the architect and the entire charges for repeated testes, if ordered shall be borne by the constructor.

It shall be obligatory for the contractor to furnish certificate, it demanded by the architect, from manufacturer of the material supplier that the work has been carried out by using their material and as per their recommendations.

All materials supplied by the employer / any other specialist firm shall be properly stores and the contractor shall be responsible for its safe custody until they are required on the works and till the completion of work.

Unless otherwise shown on the drawings or mentioned in the "Schedule of Quantities" or special specifications, the quality of materials, workmanship, dimensions etc., shall be as specified herein under.

The contractor without any extra cost for carrying out field-tests on materials shall provide all equipment and facilities.

Unless mentioned specifically, all materials used in the construction shall conform to the relevant Indian standards published by bureau of Indian standards.

The contractor whenever in doubt should get the materials approved by the architect, before use. A sample of approved material should be deposited with the architect.

Test certificates from the laboratory approved by the architect will have to be furnished, if so directed by him. The contractor will pay all costs for the same.

For special items to be used, the manufacturer's instruction of handling and installation shall be strictly adhered to. The contractor shall obtain, the guarantee certificate from the manufacturer and pass on the same to the owner.

Materials if supplied by the owner, shall be properly stored in the safe custody of the contractor. The same shall be carefully used and shall be properly preserved till the work is completed and handed over to the owner. Proper accounts of such materials will be maintained and will be presented for inspection and physical verification as and when requested by the owner. **Timber:**

Timber generally is to be the best of its kind, well and properly seasoned, of mature growth, free from worm holes large loose or dead knots or other defects and sawn die square and will not suffer warping, splitting or other defects through improper handling.

The wood is to be Steam beach weighting not less than 45 lbs per cubic foot with moisture content not exceeding 12% to 14%. The moisture content of timber shall be determined according to method described in paragraph 4 of IS: 287 for "maximum permissible moisture content of timber used for different purpose in different zones".

In measuring cross-sectional dimensions of the frame pieces tolerance up-to 1.5 mm shall be allowed for each planned surface.

Good quality Steam beach wood:

Steam beach wood be of good quality and well seasoned. It shall have uniform color, reasonably straight grains and shall be free from large, loose dead knots, cracks, shakes, warp, twists, bends, borer, holes or defects of any kind. No individual hard and sound knot shall be more than 1 cm. In diameter and aggregate area of all knots shall not exceed ½ % of the area of the piece. It shall be close grained and there shall not be less than 6 growth rings per 2.5 cm width.

Good quality Steam beach wood:

Steam beach wood shall be of good quality and well seasoned. It shall have uniform color reasonably straight grains and shall be free from large, loose, dead knots, cracks, shakes, warp, sound knot shall be more than 2.5 cm. In diameter and aggregated area of all knots shall not exceed 1% of the area of the piece. There shall not be less than 4 growth rings per 2.5 cm width.

Timber is to be cut to the required sizes and lengths as soon as practicable after the works are begun and stored under cover so that the air will circulate freely around it. Joinery is to be prepared, immediately after the placing of the contract, framed up (but not bonded) and stored until required for fixing in position, when it is to be bonded and wedged up. Any portions that warp or develop shakes or other defects are to be replaced before wedging up. The whole of the work is to be framed and finished in a proper and workman like manner, in accordance with the detailed drawings, and fitted with all necessary motifs straps, belts screws etc. Running bounded joints are to be cross-

tongued with teak on guese and where over 1-1/2" thick double cross tongued. Joiner's work generally is to be finished with fine class papered surfaces unless otherwise specified.

Templates boxes and moulds shall be accurately set out and rigidly constructed so as to remain accurate during the time they are in use.

Grounds are to be clean shown, free from large knots, splayed as required, plugged and fixed to walls etc. At 1'-6" centers.

Wood plugs are to be put cut on the twist. Patent wall plugs or plastic filling may be used in lieu of wood plugs with the approval of the architect.

All unexposed surfaces of timber e.g. walls ceilings, backings fillets backs of doors frames backs of doors frames, cupboard framing, grounds etc. Are to be treated with two coats of approved timber preservative like soigné, kirticite, term seal or castral or vacuum pressure impregnated with and approved water soluble timber preservative before fixing or bedding.

Timber shall be well seasoned and of the best quality Indian teak of specified species. Timber shall be considered as well seasoned, if its moisture content does not exceed the following limits.

- (1) timber for frames. 14%
- (2) timber for planking, shutters etc. . . 12%

The moisture content of timber shall be determined according to method described in paragraph 4 of IS 287 for "maximum permissible moisture content of timber used for different purposes in different climatic zones".

In measuring cross-sectional dimensions of the frame pieces tolerance up-to 1.5mm shall be allowed for each planed surface. **Carpentry and joinery:**

The carpenter and joiner shall include the finishing of all labor, materials, equipment, and appliances required to complete the work including the installation of hardware as per the drawing. The timber shall be of the quality as described on the drawings or in the bills of quantities, shall be seasoned and uniform in texture, free from fungal growths, knots, wanes, open shake borer holes, rot, decay, discoloration, soft or spongy spots, holes, rot, decay, discoloration, soft or spongy spots, hollow pockets, patch or box heart and all other defects.

Skilled workmen, using proper tools, shall carry out all the carpenter's work. All joints shall be securely nailed without splitting the wood. Wherever it is necessary the members shall be lapped or joining by g.i. stapes or extra wood blocks. All joints and nailing shall be done in neatness, and shall be approved by the architects. All assembly is exactly at right angles.

Finish woodwork and joinery including doors shall be surfaced with straight without any warp of bow and shall have smooth, well-planned faces at right angles to each other. The frame members shall be planned on the three sides exposed at right angles to each other.

All joinery work shall be securely mortised and tanned with synthetic resin conforming to I.S. 8511957. Heads, posts, transoms, mullions of door and window frames shall be made out of single pieces of timber only. The heads and posts shall be thought - tanned into the mortises of not less than 1/2". Solid wood panels of not less than 5" and not more than 8" in width shall be used and jointed together with tongue and groove joint.

All interior wood finish doors, cabinetwork shall be smoothly traded and sanded after erection, until all defects are entirely removed. Assembled door frame without sills shall be fitted with temporary stretchers. All exposed wood and plywood shall be straight-grained method grain and color and shall be approved by the architects. Interior wood finished doors cabinets and other fixed wooden equipments shall be properly installed, level plumb and true. But joints shall be avoided wherever possible; if unavoidable the joint shall be leveled. All exterior angles shall be mitered. Adjoining interior woodwork shall match and harmonies. All woodwork in contact with masonry shall be painted with bitumen paint or red oxide paint.

Joints:

All joints will be standard, mortised and tenon, dovetail, dowel, cross-halved, metered, tongued and grooved and rebated. Nailed or glued but joints, will not be permitted exceptional cases, ailed but joints will not be accepted. All joints shall be smeared with white lead.

Whenever solid wood is specified it shall be as per I.S.I. and of good quality. The type of wood shall be got approved before collecting the same on site. Fabrication of wooden members shall be started only after approval. It shall be free from large, loose, dead or cluster knots, flows, shakes, wraps, bends or any other defect. It shall be uniform in substance and of straight fibers as far as possible. It shall be free from rats, decay, harmful fungi and other dejects of nature which will affect the strength, durability of it usefulness for the purpose for which it is required. The color of wood shall be uniform as far as possible. The scantlings planks etc. Shall be seen in straight lines and planes in the direction of grain and have uniform thickness.

Plywood:

Plywood for general purpose shall confirm I.S. 303 MR grade & I.S. 710 B.W.P. / marine grade as specified. It shall be formed with 0.8 mm. Thicknesses commercial face veneers and 1.5 mm. Thicknesses. Intermediate veneers in two opposite grain direction shall be 1:1. The moisture content shall not be more than 12.5% by mass. It shall either be kit ply make or other equivalent approved make. Where B.W.P. grade is specified it should be boiling waterproof confirming to I.S. standards.

The plywood for general purpose shall conform to is I.S. 303 MR grade & I.S. 710 B.W.P. / marine grade as specified Cementing together thin boards or sheets of wood into panels makes plywood.

There is always an odd number of layers 3,5,7,9 ply etc. The plies are placed so that grain of each layer is right angle to the grain in the adjacent layer.

According to is I.S. 303 MR grade & I.S. 710 B.W.P. / marine grade as specified the plywood for general purpose shall be of three grades namely I.S. 303 MR grade & I.S. 710 B.W.P. / marine grade as specified depending upon the adhesives used for bonding and veneers, and it will be further classified into six types namely aa, ab, ac, bb, bc and cc based on the quality of the two face, each face being of three kinds namely, a, b and c.

I.S. 303 MR grade & I.S. 710 B.W.P. / marine grade as specified formed with 0.8 mm. Thickness commercial face veneers and 1.5 mm. Thick intermediate veneers in to two opposite grain direction. The moisture content shall not be more than 12.5 % by mass. Where B.W.P. grade is specified it should be boiling waterproof conforming to Indian standards. **Laminates:**

All the laminate to be used shall be of 1.0 mm (or 1.5 mm or 0.5 mm where specified) thickness in approved the color and shade as approved and specified by the architect. It

shall be matt finish manufactured by recommended makes as per sample shown by the consultant unless otherwise specified. It shall satisfy all the I.S.I. standards for melamine coated laminated fiber board's before the use of such fiberboard laminated. The contractor shall have to take approval of the department of each sheet of the laminates.

Fixtures and fastenings:

The fixtures and fastening, that is, butt hinges, tend strap hinges, sliding door bolts, tower bolts, door latch, bath room latch, handles, door stoppers, casement window fasteners, casement stays and ventilators catch shall be made of the metal as specified in the item or its specifications.

They shall be of S.S., S.S. brush finish, iron, brass, aluminum, chromium plated iron, and chromium plated brass, copper oxidized iron, copper oxidized brass or anodized aluminum as specified.

The fixtures shall be heavy type. The fixtures and fastenings shall be smooth finished and shall be such as will ensure ease of operation.

The samples of fixtures and fastening shall be got approved as regards quality and shape before providing them in position. Brass and anodized aluminum fixtures and fastenings shall be bright finished.

Screws, nails, bolts will be of brass or other non-corrosive metal. In hardware, they will match the finish of the hardware item. Nails, in a finished surface shall be neatly punched and the hole filled with wood filler matching the finish. Screws in a finished surface will be round head, raised head or sunk beneath the surfaces and the hole plugged with a wood plug with matching color and grain of the wood surface as directed.

S.S. fittings should be proper polish finished.

Screws, nails, bolts, will be of brass or non-corrosive metal. In hardware, they will match with the hardware items.

Nails, in a finished surface shall be neatly punched and the holes filled with wood filler matching the finish. Screws, in a finished surface will be round head, raised head or sunk beneath the surfaces and the hole plugged with a wood plug with matching color and grain of the wood surface, unless especially detailed

Hardware

Hinges, locks, latches, door tracks etc. Shall be as specified and as far as possible, by the manufacturer specified. In any variation of this quality of the substitute shall be equal to or better than the original specified, and the samples shall be submitted to the architect for prior approval.

Hardware and metals

The hardware throughout shall be of approved brand and supply well made and equal in every respect to the samples deposited with the architect. The contractor may be required to produce and provide samples from many different sources before the architect is able to make the decision and he should allow in his rates for doing so.

Fittings generally shall have a brass finish or powder coated finish unless otherwise specified and should be suitable for their intended purposes.

Screws are to match the finish of the article to be fixed and to be rounded or flat headed or counter sunk as required.

Cover up and protect at the brass or powder coated surfaces with a thick grease or other suitable material, renew as necessary and subsequently clean off and clear away on completion

All steel, brass, bronze, aluminum and stainless steel articles shall be submitted to a reasonable test for strength. If so required by the architect at the contractors expenses.

Door closers

The overhead door closer shall be of standard make as listed by the architect. The overhead door closer shall be of color as approved by the architect. Fixing of the overhead door closer shall be done by and experienced worker preferable from the principal supplier of the item.

After successful installation of the overhead door closer the same shall be checked for speed of door closing. The contractor shall make necessary adjusted operating mechanism as per manufacturer's guidelines to arrive at most suitable operating speed. The selected operating speed should remain constant on all repeated operations. If an overhead door closer is found to lose its adjusted operating speed often during warranty period then the shall have to be replaced with a new piece without charging any extra.

In case of a steel frame door the overhead door closer shall have to be mounted on a special plate supplied by the manufacturer. No extra payment shall be due for such mounting plate.

The rate shall include all materials, labor, required civil work etc. Complete and shall be paid per no. Of overhead door closers installed.

Paints:

Lime for lime wash, dry distemper, oil bound distemper, cement primer, oil paint, enamel paint, flat oil paint, plastic emulsion paint, anti-corrosive primer, red lead, water-proof cement paint shall be from an approved manufacturer and shall conform to the latest Indian standard for various paints. Ready mixed paints as received from the manufacturer without any admixture shall be used, except for addition of thinner, if recommended by the manufacturer. However, if ready mixed paint of specified shed or tint is not available then only ready mixed paint with approved strainer will be allowed. In such a case, the contractor shall ensure that the shade of the paint so allowed shall be uniform.

All the paints shall met with following general requirements:

Paint shall not show excessive setting in a freshly opened full can and shall easily be redispersed with a paddle to a smooth homogeneous state. The paint shall show no curdling, levering, cracking or color separation and shall be free from lumps and skins.

Paint as received shall brush easily; possess good leveling properties and show no running or sagging tendencies.

The paint shall not skin within 48 hours in a three quarters filled closed container.

The paint shall dry to a smooth uniform finish free from roughness, grit, unevenness and other imperfections.

General: wherever scaffolding is necessary, it shall be double scaffolding.

The surface shall be thoroughly brushed free from mortar droppings, and foreign matter. All steel work shall be cleaned of loose rust, mill scales, etc. So as to expose the original surface. All broken edges, cracks, loose-plaster and wavy surface shall be brought up either by patch plasterwork or by plaster of Paris.

All materials viz. Dry distemper, oil bound distemper, oil paint, flat oil paint, synthetic enamel paint, plastic emulsion paint, cement primer, red lead and other primers and metallic paints shall conform to respective i.s. specifications and shall be obtained from approved manufacturers.

Painting - Flat / Plastic emulsion etc.:

Ready mixed flat oil paint, plastic emulsion paint, ready mixed synthetic enamel paint, aluminum paint, etc. Shall be brought in original containers and in sealed tins, if for any reason thinner is necessary, the brand and quality of thinner recommended by the manufacturer or as instructed by the architect shall be used.

The surface shall be prepared as specified above and a coat of approved primer shall be applied. After 24 hours drying, approved or specified quality paint shall be applied evenly and smoothly. Filler putty coating may be given to give to give a smooth finish. Each coat shall be allowed to dry out thoroughly and then lightly rubbed down with sand paper and cleaned of dust before the next coat is applied. Number of coats shall be as specified in the item and if the finish of the surface is not uniform, additional coats as required shall be applied to get good and uniform finish at no extra cost. After completion no hair marks from the brush or clogging of paint puddles in the corners of panels, angles or moldings etc. Shall be cleaned of stains.

Pigmented priming coat (emulsion thinned with water) followed by three or more finishing coats of plastic emulsion paint. Pasted filler to be applied after every coat exempting the final finishing coat and sanded. When the final coat is applied, if directed the surface shall be rolled with a roller or if directed, it shall be stippled with a stippling brush.

Enamel paints

Oil paints shall be of first quality and of the specified color and shade, and as approved. The ready mixed paints shall be only used. However, if ready mixed paint of specified shade or tint is not available while ready mixed paint with approved strainer will be allowed. In such a case, the contractor shall ensure that the shade of the paint so allowed shall be uniform. **All the paints shall meet with the following general requirements:**

Paint shall not showed excessive setting in a freshly opened full can and shall easily be redisbursed with a paddle to a smooth homogeneous stage. The paint shall show no curdling levering, caking or color separation and shall be free from lumps and skins.

Paint as revived shall brush easily; possess good leveling properties and show no running or sagging tendencies.

The paint shall not skin within 48 hours in a three quarters filled closed container.

The paint shall dry to a smooth uniform finish free from roughness, grit, unevenness and other imperfections.

Ready mixed paint shall be used exactly as received from the manufacturers and generally according to their instructions and without any admixtures what so ever.

French polish:

The French polish of required tint and shape shall be prepared with the below mentioned ingredients and other necessary material:

- (i) denatured spirit of approved quality
- (ii) chandras
- (iii) shellac
- (iv) pigment

The French polish so prepared shall conform to is 348.

French polishing:

French spirit polish shall be an approved make conforming to i.s.: 348. If it has to be prepared on site, dissolving 0.7 kg shall make the polish. Of best shellac in 4.5 liters of mentholated spirit without heating. To obtain required shade pigment may be added and mixed.

Surface shall be cleaned. All unevenness shall be rubbed down smooth with sand paper and well dusted. Knots, if visible, shall be covered with a preparation of red lead and glue. Resinous or loose knots and gaps shall be filled with seasoned timber pieces and made level with rest of the surface. Holes and indentations on surface shall be filled with putty made of whiting and linseed oil. Surface shall be given a coat of filler made of 2.25 kg. Of whiting in 1.5 liter of mentholated spirit. When it dries, surface shall again be rubbed down perfectly smooth with sand paper and wiped clean.

Piece of clean fine cotton cloth and cotton wool made into shape of pad shall be used to apply polish. The pad shall be moistened with polish and rubbed hard on the surface applying the polish sparingly but uniformly and completely over the entire surface. It shall be allowed to dry and another coat applied in the same way. To give furnishing coat the pad shall be covered with a fresh piece or clean fine cotton cloth, slightly damped with mentholated spirit and rubbed lightly and quickly with a circular motion, till the finished surface attains uniform texture and high glass.

Wax polishing:

Wax polish shall either be prepared on site or obtained ready made from market. Polish made on the state shall be prepared from a mixture of purr bees wax, linseed oil, turpentine oil and varnish in the ration or 2:1 ½:1: ½ by weight. The bee's wax and the boiled linseed oil shall be heated over a slow fire. When the wax is completely dissolved the mixture shall be cooled till it is just warm, and turpentine oil and varnish added to it in the required proportions and the entire mixture is well stirred.

Surface shall be prepared as described under "French polishing" except that the final rubbing shall be done with sand paper, which has been slightly moistened with linseed oil.

Mixture or polish shall be applied evenly, with a clean cloth pad in such a way that no blank patches are left, and rubbed continuously for half an hour. When the surface is quite dry a second coat shall be applied in the same manner and rubbed continuously for an hour or until the surface is dry. Final coat shall then be applied and rubbed for two hours or more if necessary, until the surface has assumed a uniform glass and is quite dry showing no sign of stickiness when touched. Glass rubbing must be continuous and with uniform pressure and frequent change is direction.

Glass:

All glass shall be of best quality, free from flaws, specks, bubbles, veins, smokes, air holes blisters and other defects. The thickness and kind of glass to be used shall be as

mentioned in the item or as shown in detailed drawing. The thickness of glass panel shall be uniform. All glass shall be of approved make by the architect and conforming to IS 3548.

All glass shall be float glass of the best quality, free from specks, bubbles, smokes, veins, air holes, blisters and other defects. The kind of glass to be used shall be as mentioned in the item or specification or in the special provisions or as shown in detailed drawings. The thickness of glass panel shall be uniform. All glass to be approved manufacture complying with IS: 3548-1966 or as per approved quality and sample.

The compound for glazing to metal is to be special non-hardening compound manufacture for the purpose and of 9 brands and quality approved the interior designer.

In cutting glass, proper allowance shall be made for expansion. Each square of glazing to be in one whole sheet and after cutting the edges to be properly filled.

On completion, clean all glass inside and out, replace all cracked scratched or broken panes and leave in good condition to the satisfaction of the architect.

The contractor shall furnish all labor, materials, and equipments required for the installation of glass and glazing items.

The glass shall be of the type, quality and substance specificity in the bills of quantities.

In case of the glass being supplied by the owners, the contractor shall take the delivery of the glass at site and shall be responsible for proper handling and stacking. We shall insure glass against theft, fire, etc.

The contractor shall replace at his own expense all broken, damaged or disfigured glass caused in the execution of the work of faulty installation, before the virtual completion of the work.

Patterned or translucent glass shall be 4 mm. In thickness and shall be approved by the architects. Sheet glass shall be in 5 mm. In thickness. Wired glass shall be 6 mm. In thickness.

The putty used for glazing metal door, window or ventilator shall conform to I.S. 420:1953.

Before installation of the glass, the contractor shall ensure against the following:

All glazing rebates shall be square, putty, true in plane, clear, dry and free of dust. The frames shall be adjusted before glazing. The weight of the glass in side hung casement causes it to drop slightly on its hinges. Before glazing it shall be set in slightly high position in its frame. Glass edges shall be clean and cut to the exact size, chipped or damaged edges shall be rejected. Sashes shall be glazing in the closed position and shall not be open till the putty is set.

The glass shall be set in teak wood beading or metal glazing chips and so installed to achieve water tightness.

The platter glass shall be bedded on strips of leather or felt turned over the two sides of the glass to form packing between the glass and the metal coating. The ground glass shall be getting with smooth surface outside.

Glazing large panes of glass, or when heavy wind pressure is experienced, glazing bead may be used instead of front putty. In this case putty shall be applied to the face of the bead, which is in contact with glass. Putty would also be necessary, at the back.

Beads shall be of timber, rustproof steel or aluminum and shall have mitered corners. The position and size of the bead may depend on the thickness of glass used. The beads shall be fixed with screws 0" apart.

On completion of the job, all glass shall be thoroughly cleaned. All paint or other marks to be removed.

SPECIFICATION FOR WORKMANSHIP

Painting and polishing: various readymade paints:

The surface to be painted shall be cleaned and all cracks, holes and surface defects shall be repaired with plaster of Paris. All irregularities shall be sand papered and wiped clean. The surface so prepared must be dry and free from dust.

The priming coat shall be applied over in the manner recommended by the manufacture in case of special paint. When no priming coat is specified by the manufacturer, putty composed of powdered whitening chalk mixed with double polished linseed oil of required workable consistency shall be applied to prepare a good, hard background in case of undecorated surfaces. The surface shall be then rubbed down again with a fine grade sand paper and made smooth.

The paint shall be of 1st quality and of specified color and shade and as approved.

Ready mixed paint as received from the manufacturer without any admixture shall be used, except for addition of thinner, if recommended by the manufacturer. However, if ready mixed paint of specified shade or tint is not available while ready mixed paint with approved strainer will be allowed. In such a case, the contractor shall ensure that the shade of the paint so allowed shall be uniform.

Polishing to wood work:

Woodwork to be polished shall be finished smooth with plane. It shall then be rubbed smooth with medium and fine sand papers. In no case sand paper shall be rubbed across the grains. All holes, cracks, open joints and small defects if all allowed to remain by the architect shall be stopped with putty made from pure whitening mixed to the proper consistency with linseed oil.

Polish shall be applied in very thin coats with special fine haired varnishing brushes. Before applying first coat after stopping, the wood surface shall be rubbed down lightly with a fine sand paper taking care to rub along the grains and to leave the color even. The number of coats shall be as specified in the item.

Measurement:

No separate measurement and payment shall be made for such finishing work. The cost of such finishing shall be included in the rate of related item of woodwork. But if the item is to be carried out independent item of measurement shall be as per is 1270.

Melamine polishing to wood work:

All unevenness shall be rubbed down to smooth with sand paper and surface shall be cleaned of dust.

The wood to be polished should be first painted with filler composed of a mixture of whitening and mentholated spirit to obtain a good glass surface. The surface shall be again rubbed down for making perfectly smooth with sand paper.

The number of coats of melamine polish shall be as specified in the item. On the woodwork a pad of woolen cloth covered by fine cloth shall apply a thin coat of melamine

polish. The pad shall be moistened with polish and rubbed on a surface in a series of overlaying circles, applying the polish uniformly over the entire area to give even surface. A trace of linseed oil on the face of pad facilitates this operation. The surface shall be allowed to dry and the remaining coats shall be applied in the same manner to finish off. The pad shall be covered with a fresh piece of clean fine cloth, slightly damped with mentholated spirit and rubbed lightly and quickly with circular motion. The finished surface shall have uniform texture and high gloss. The melamine polish shall be applied with spray gun and even coating shall be applied to get the very good quality of finishes.

Measurement:

No separate measurement and payment shall be made for such finishing work. The cost of such finishing shall be included in the rate of related item of woodwork. But if the item is to be carried out independent item of measurement shall be as per IS 1270.

GENERAL & IMPORTANT NOTES

1 GENERAL NOTES:

- (i) ~~Unless otherwise~~ specified in these tender documents mode of measurements specifications etc. shall be as per relevant IS codes.
- (ii) Source of materials / samples / brands / makes etc. shall be got approved from the Architects / Bank before using. In case of deviations, decision of the Bank shall be final and binding and shall not be open for arbitration.
- (iii) The Architects have their specific role / duties / rights as defined in these tender documents. However in the event of any dispute arising out of differences between the opinions of the Architects and also their role/ duties/rights, the Banks' decision shall be final & binding on the Architects and the Contractor and shall not be open to arbitration.
- (vi) The Contractor will extend full co-operation, support and all required assistance to Architect / Bank for discharging their duties and responsibilities efficiently and effectively.
- (vii) The contractor has to supply and adhere to the specific makes and specifications of all the items, which are mentioned in the separate list of approved makes. Any work found not as per the tender specifications and list of approved the contractor has to replace the same without any delay. The contractor is instructed of get approval of all the materials to be used on this site before starting the work. He should provide different sample of material for approval, before execution of work.
- (viii) All quantities indicated in the tender are approximate & are likely to change. The contractor must take actual measurement at site and billing shall be done as per the actual measurement of the work done at site.
- (ix) Work has to be got executed at site in coordination with various agencies working at site.
- (x) The contractor is instructed to get the approval of the materials to be used on this site before starting the work. He shall provide different sample of materials for approval before execution of the work
- (xi) All material have to be used in full size/length only. Joints should be avoided as far as possible.
- (xii) Any item mentioned in the BOQ with "TO THE SHAPE" will have measurement of onsite executed to the shape area only.
- (xiii) Making various levels & line out for total layout on site for the items in scope of the work shall be done by the contractor at his own cost.
- (xiv) MTC (Manufacturer Test certificate) Where ever applicable shall be arranged & submitted by the contractor. Testing of wood for moisture, knot % etc. shall be carried out by the contractor at his own cost.

2. IMPORTANT NOTES:

- (i) **The contractor's qualified & authorized representative shall remain on site during the entire execution process for coordination with various agencies / Architect / Bank & execution of work**

- (ii) The site shall be cleaned on day to day basis & all debris shall be disposed away at the location beyond the limit as approved by the local authority.
- (iii) Hidden measurement. It is contractor's responsibility to get the measurement checked immediately on completion of such items. This shall be done before finishing the same The Architect shall be provided with such details well in advance so that the other work is not held up due to last moment action.
- (iv) Before starting the contractor shall mark out the plan & levels of the false ceiling, partitions etc. in coordination with other agencies on site.
- (v) The rates quoted shall be inclusive of all taxes, Duties, Octroi, Transportation, Delivery, Installation, Testing, Commissioning etc. complete at the site. No extra will be paid for any kind of taxes. However the service tax will be paid extra as the works contract.
- (vi) The entire job shall be executed in total coordination with the other agencies working on this project & also with landlord, bank etc.
- (vii) Architect of the project shall be kept informed about the progress of the work at various stages
- (viii) The contractor shall arrange on his own for lighting & plug point with socket & electrical wiring, DB's etc. required during entire execution process. However supply at point shall be provided by the bank / landlord
- (viv) The contractor shall prepare all loose furniture items at his workshop only & deliver the same to the site at appropriate time as instructed by the architect
- (vi) Any Hidden item MUST be photographed and need to be sent via social media or CD to Architect / Bank
- (xvi) Billing Process:

Along with final bill the contractor MUST submit:

- Abstract in tender BOQ format only
- schedules for detailed measurement sheet for all items (in detailed break up)
- ~~separate as built drawings (Min. A3 size) marking exact locations & putting exact measurements of all works executed on site~~
- original insurance policies as per tender terms
- completion certificate
- Inspection & completion certificates for all types of false ceiling - Test report for Toughen glass - copy of LOA etc.
- All documents shall carry contractor's signature & seal with address. - All documents shall be submitted in 1 plus 1 copies.
- The contractor shall also provide all measurement sheet in soft copy (in Excel format)
- The contractor shall submit the purchase bill copy of major items used in the project

IMPORTANT: ALL DOCUMENTS SHALL BE SUBMITTED AT ONCE (NOT IN PIECE MILL MANNER) ALONG WITH FINAL BILL & SHALL BE DULY SIGNED BY PUTTING

COMPANY'S ADDRESS SEAL

APPROVED MAKES FOR VARIOUS MATERIALS IN WOOD WORK:

No.	Particulars and Specifications	Approved Make/ model
A	Wood / Block board / Plywood / Flush doors /Laminates / Veneers / Solid surfaces	
I	Wood:	
1	For External use	Steam Beach - 1 st quality imported, 95 % in even color without knots, joints & bend wood as suggested & in full length / size only
2	For Internal use	Marandi - 1st quality, without knots, joints & bend wood as suggested & in full length / size only
II	Plywoods / Block boards / Laminates / Veneers / MDF / Particle boards / Acrylic solid surfaces	
1	Commercial Quality - Block boards (IS 1659), Ply wood (IS 303) / Water proof ply (IS-710) / Flush door (IS 2202) Part - I	All plywood & block boards shall be with CM/L number only & shall not as per or not as per generally confirming to Duro / Anchor / Archid / Century / Green / Mayur
2	Laminates (IS-2046)	On all horizontal & vertical surfaces in finish & shade on approval basis
	Balancing (0.5 to 0.7 mm thick) / Regular & Special finish 1.0 mm & 1.5 mm as specified	Airolam / Century / Bell / Century / Blum / Formica / Greenlam / Merino / Silicon / Sunmica / Vir
3	Veneers	On all horizontal & vertical surfaces in finish & shade on approval basis - Minimum Rs. 120/- per Sq.Ft. net Rate Duro / Century / Durian / Garnet / Green / Timex / Vir
4	MDF / Particle boards - IS 12406 - 1988	Exterior grade (water proof) manufactured from agro based lignocelluloses fibers
	M.D.F. board	Action (Tesa) / Duratuf / Green / Merbock / Nuwud
	Particle boards	Deco board / Novapan
5	Acrylic solid surface	Bendable / Thermo Transforming - On approval basis only
		Dupont / LG - Hi-Macs / Luxor / Merino / Neonnex / Samsung
B	Hardware items	
I	General Hardware items	
1	Adhesives	Araldite / Blue coat + / Fevicol SH / Mavicol / Royal bond
2	Screws	Sheet Metal / Wood GKW / Haffele / Nettle fold / R.K. / Sharp
3	Nails	Fresh & without rusting Chakra / Mehta / Sun
4	Sealant	Choksey / Pedilite / Rhone Poul
II	Locks	

1	Auto (self) latch Lock	For SWS counters Ebco - P - ALL1 - 22 or Eq. in Hafele / Hettich
2	Multipurpose group Lock	Round housing in vertical or horizontal mounting as req. In all item - in group only Ebco - E-MPL1-22/E-MPL1C-22 or Eq. in
3	Night latch	Door set / EG / Europa / Godrej / Hafele / Hettich S.S. brush / matt finish Europa 8010 NS / Doorset - NL 180 S/S. / Godrej - 8812
4	Cylindrical lock	S.S. brush / matt finish Ebco - C120SS Europa 8010 NS or C120SS / Doorset - NL 180 S/S, / Godrej 3792 - with key & 3786 for keyless / Hafele / Hettich
5	Mortise dead lock (two way)	6 lever - pin cylinder type with flush type key hole Doorset - HL 170 or ML 102 S / Dorma / Ebco / Godrej - Matiz 8083 or 8815
6	Mortise lock with door handle	Dorma / Doorset - ML 102 S / Ebco / Godrej - 8815 or Matiz 8083
7	Allen Key	Prince / Riddhi / SSL
III	Fixtures	
1	Hinges	S.S. brush / matt finish
	For Storage units	3" or 4" x1/2"x3/4" x 1.2 mm th. - 3 or 4 nos. as per the weight / size of the shutter
	For Cabin Doors & Flap doors	5" or 6: X1"X1"x1.8 mm - Min. 4 or more nos. as per the weight / size of the door
		Aks hvy. Cut / EBCO / Garg premium / Hafele / Hettich / Suzu matt
2	Drawer sliders	Premium quality ball baring - full extension - 45 x 25.4 mm th. & 0.0775 kg / inch weight - in Zinc coating / Powder coated finish - 18"/20"/22" long as req.
a	Telescopic	EBCO - STDS35(I)35 / STDS45(I) / STDS50(I)35 / STDS60(i)35, Godrej / Hafele / Hettich
b	Bottom channels	EBCO - BMDS 35/ BMDS 37/ BMDS 55/ BMDS 60
3	Sliding Mechanism	For sliding shutters Hanfa / Orbit
4	Tower bolts ("L" stopper)	"L" Stopper / SS brush / matt finish - 3" up to 3' / 4" for 3' to 5' & 5" for 5' to 7' shutter height Cent / Flora / Oswal / Riddhi / Rolex
5	Handles	"C" or bow shape - S.S. 202 - Matt finish- Size as per the

		size of shutter / with common pin for a pair
	For Storage units / drawers / door / Flap doors	Acme / Corel / Ebco / Godrej / Korsal / Orchid
	Profile type	Ebco / Hafele / Hettich
6	Magnet	Small for shutter Up to 3' shutter & big for shutter up to 3' to 7'
		Bentex / Honda / Meesha / Supreme
7	"D" / Pocket bracket	8 mm & 12 mm th. X 50 mm - SSL plated
		Flora / Riddhi / Oswal
8	Studs	SS matt finish - length as req.
		Deco well
IV	Door Opening Fixtures	
1	Door closers	Silver in color - on approval

		Golden / Hardwin / Ozone / Scorpio
	For fire rated door @ 60 Kgs. in weight	Godrej - 1938 / Hardwyn - Triton
2	Floor spring	Hold open type-heavy duty/ / as per door size & weight
	60 KG	Door Set / Dorma / Ebco / Godrej - 7477 / EG Sterling - FS
		3000 / Hardwyn - M 74 / Ozone - 7400
	80 KG	Door Set / Ebco / Godrej - 8293 / Hardwyn - M 74 / Ozone -
		8400
	100 KG	Door Set / Ebco / Godrej - 8294 / Hardwyn - M 76 / Ozone -
		9400
3	Door Stopper	SS brush / matt finish - push type only
		Corel / Ebco - DS1 / E.G.I.L. - Spring type - Sterling / Ozone
4	Patch fittings for door & fixed glass partition (top/bottom/ patch, pivot, lock, L arm, L connect, connector, floor spring, handle, plastic profile	As per the req. & detailed drawing
		Dorma - XL C series / Ebco / Hafele / Ozone - OPF series

V	Computer related fixtures	
1	Cable manager	S.S.L. plated - 50 or 60 MM dia. - on approval basis
		EBCO - CO60ZN1 zinc 60 or 80 mm dia as req. CO 60 ZN1 /
		CO 80 ZN1 / Nova / Rolex

NO
1 /
2 /
3. T
C
A
D

2	Key drawers	heavy ball bearing slide - 25" long + soft pad - with or without mouse tray as required.
		EBCO - KTE 1 -45 M / Jumbo - KBJT / Featherlite / Hettich / Innofitt
3	CPU trolley / hanger	M.S. black powder coated with castor / wall mounted as required
		EBCO - Cpusm / Featherlite / Hettich / Innofitt - side
		mounted IS CPU HL SM / Ziproc - 4/2-SMCS
4	Leg rest	Read made with adjustable angle - Chrome plated with Heavy duty plastic top
		EBCO
VI	Aluminum Sections / ACP / Perforated sheet / Skirting	
1	Aluminum Sections	Banko / Hindalco / Indal / Jindal
	For Partitions	2"x1"x1.6 mm
	For Paneling	1"x1"x1.2 mm
	For Doors	Size as specified in BOQ x Minimum 2.65 mm th.
2	Perforated sheet	As per the manufacturer's specifications
		EBCO Alu . shutter grill ASG
3	ACP Sheets	3 mm th. Exterior grade
		Alu bond / Alu Décor / Armstrong / Euro bond / Flexi bond / Timex
4	Aluminum skirting	With End caps - As per manufacturer's specifications
		Ozone or Eq.
5	UPVC Skirting	With End caps - As per manufacturer's specifications
		Rehau or Eq.
5	Gasket	PVC or EPDM - As per requirement

VII	Glass & Mirrors	Of appropriate thickness (as suggested in BOQ) & shall be
		in full size only as suggested as per mfg. company's
		specifications
		Aasahi / Modi guard / Saint Gobain
VIII	Finishes	
1	Polish	Melamine matt finish polish as suggested
		Asian Paints
2	Paints	Satin enamel / Flat / Duco / Exterior / Cement paint /
		Distemper / Royal shine luxury emulsion - shade & finish as
		suggested
a	For wall / ceiling / furniture etc.	Asian Paints / Burger / ICI Dulux / Nerolac
b	For Wood - PU paint (Pigmented / paint & polish)	Polyurethane paint
		Asian paints - Emporia PU / Sirca
c	Textures plaster / Spray paint	On sample approval basis - to be executed by company's
		approved applicator only
		Alltek / Asian / Durotex / Luxture / Nerolac
d	Powder coating	Shade, finish & mfg company - on approval basis - 55 to 65
		microns by giving pretreatment the material and phosphate before powder coating and thermo set powder
		coating by applying epoxy hybrids in suggested shade /
		finish - by seven tank process only
e	Color anodize	Shade, finish & mfg company - on approval basis
f	Wall putti	Birla white / J K white
IX	Foam / Rubber / Tapestry	
1	Rubber	Pencil hole various thickness Geo
2	U foam	40 density - various thickness as req.
		Feather foam / Sleep well / Spring well
3	Fabric / Upholstery	Shade / Design on Approval basis
	For Chairs / Display board / Setti	Rs. 360 / - per meter - Net rate
	For Sofa	Rs. 660 / - per meter - Net rate
X	Furnishing material	
1	Roller / Vertical blinds	On approval basis / as / basic rate for fabric given in BOQ
		Hunter Douglass / Mac / Marvel / Vista
2	Wall paper	On approval basis / as / basic rate for fabric given in BOQ
		Asian (Nilaya) / Excel - Streamline / Sangestu / WK Stone
		(Gaenari)
	Vinyl	Only approval basis only including surface preparation
		3 M India

4	Film	Only approval basis only including surface preparation 3 M India / Garware
XI	Accessories / Signage	
1	Toilet accessories	304 / 316 Grade SS Chase / Deco Well / Kich
2	Signage	SS matt finish with inlay - visual format - 120 mm x 120 mm x 1.5 mm th. Chase / Deco Well / Kich
XII	False Ceiling	All components including all hardware items of the false ceiling systems shall be used of the same make of the false ceiling system. Any local material shall not be used for any part of the ceiling system.
1	Gypsum Board Framing with complete system	Gyproc (Saint Gobain), USG Boral Gyp steel ultra (Saint Gobain), USG Boral Ultra frame system
2	Calcium silicate Board Framing with complete system	Hilux / Ramco Fuji or equivalent
3	Mineral fiber tiles ceiling with complete system	Armstrong/Saint gobain/USG

Note:

[a] Where other Material are proposed to be used these should be got Approved from the Architect before execution of particular item. In case of Non-Availability of any material of specified make, the Alternative equivalent make should be used only after it is Approved in writing by the Employer or the Architect. The Material shall be used in preferential Order only

[b] Before starting of work contractor must get all samples/make approved from Architect before using at site

[c] Consultants reserve the right to add or delete name of any manufacture as and when required.

[d] Consultants reserve rights to select any of the specified brands mentioned above. [e] Contractor should get the sample approved before execution.

**BILL OF QUANTITIES
(NOT TO BE FILLED)**

PROJECT: SBI, PARLEPOINT BRANCH, SURAT**BOQ FOR FURNITURE WORKS AT SBI, PARLEPOINT BRANCH,SURAT**

SR.NO	ITEM/ DESCRIPTION	QTY.	UNIT
1	False Ceiling	115.00	sq.mt.
	Providing and fixing 12.5mm thick tapered edge gypsum board false ceiling in plain or curve profile and as per architects drawings in proper line and level with the entire ceiling support frame work comprise of Gypsteel ultra (saint gobain) placed approximately as per co.specifications centre to centre in grid or as required,with all hangers, angles, members to be of 18 gauge approved quality G.I.sections,with all screens for jointing framing sheets (wherever necessary) and fix to framing with stainless steel screws of approved quality, properly finished. However the rate to include making necessary cut outs/openings for light fittings, AC grills etc complete.These cut outs to have perimeter channel of size 0.5 mm all around and supported suitably. Item to include 2 coats of acrylc emulsion paint with putty. Recessed strip shall be finished with high gloss blue shade PU paint		
1A	Same as above but False Ceiling Running Patta (Less than 6" including paint)	20.00	r.mt.
2	Grid ceiling	20.00	sq.mt.
	Mineral fibre tile grid ceiling using Armstrong tile, grid system, suspension system and accessories. Item to include cut outs/ openings for light fittings.		
	a) Tiles - Dune microlook 600x600 mm (Armstrong)		
	b) Suspension system - Silhoutte mid-range perimeter trim 3000x19x19 mm wall angles (6mm black reveal)		
	c) Suspension system accessories - M6 anchor fastner, vertical hangers (26x26x25x1.2 mm), Pre straightened hanger GI wire (2.68 mm dia), Hook clip (0.8mm thick).		
	Suspension system accessories to be at maximum 1200 mm c/c and not more thant 450mm on main runner from the adjacent wall		
	Necessary cutouts shall be provided wherever required. Visible area shall be measured in sqft only (No deduction in area for cutouts).		
3	Branch manager's table	1.00	Nos
	Providing and fixing manager's table in size of (1800mmL X 750mmW) (6'-0"X2'-6") including side unit, drawer unit, CPU stand, foot rest, key board, cable manager according to following description		

	<p>Table top : 30mm thk. Table top will be made of 18mm+12mm exterior grade MDF board. The top and sides to be after finished with 4mm thk. Teak Veneer with high gloss PU. the bottom surface will be finished with base white oil paint. All corners will have 45 degree joint in veneer.</p>		
	<p>Table side: 30mm table side will be made with 18+12mm Exterior grade MDF. The exterior sides and edges visible will be finished with 4mm thk. Teak Veneer with high gloss PU . Other side which is not visible from outside is to be completed with base white oil paint.</p>		
	<p>Modesty panel: modesty panel will be made of 12mm thk. Exrior grade MDF of size shown in drawing. The frint side will be covered with 4mm thk. Teak Veneer with high gloss PU. the back side will be finished with base white oil paint.</p>		
	<p>Drawer unit: making drawer unit of 600mm (H) x 400mm (W)x 500mm (D) (1'-10"H X 16"W X 1'-9"D) (excluding legs). The unit will be made in 18mm thk. Exterior grade MDF Considering 3 drawers with pariscopic channel, drawer fascia will have 4mm thk. teak veneer in high gloss PU finish selected by architect, wooden beading, handles & hardware etc. complete as per design. 50mm (2")high 4 nos. SS legs to fixed on base of unit. Other internal surface is to be finished with white oil paint.</p>		
	<p>Side unit:- Providing and fixing of side unit with openable shutters in 3 equal parts. side top and front edge will be covered with 4mm thk. teak veneer with high gloss PU finish. top and sides will be kept in level with table top as per drawing. The thickness of the front edge will be kept 30mm. The unit with shutters will be 1050mm (L) x 400mm (W) x 650 mm (H) (3'-6"(L) x 16" (W) x 25-1/2" (H)) with internal shelves, 1mm thick solid core white laminate as per selection & approval, hardware & 12mm (1/2") teak wood beading as per the requirement of drawer unit. the internal surfaces will be painted with oil paint.</p>		
4	back unit	1.80	r.mt.
	<p>Making 1800mm (L) x 900mm (H) x 400mm (D) (6'(L)x3'-0"(H)x 16"(D)) back unit in exterior grade MDF board for BM cabin as per design. 4mm thick teak veneer with high gloss PU finish will be applied on top and external edges. the thickness of the top edge will be 30mm without veneer. The unit has four shutters of equal division with internal shelves in two levels, necessary hardware, finished with 4mm teak veneer with high gloss PU coating, handle, lock etc. complete on external side and internal sides will be finished with base white oil paint. The veneer work includes fitting, cutting, bending, buffing etc. complete.</p>		
5	Single window Counters (excluding side partitions)	2.00	Nos.

	Making single window counters with working table of 1350mm (L) x 750mm (W) x 1500mm (H) (4'-6"(L)x2'-6"(W)x5'-0"(H)) to be made as per architect's design & as per following description including side board, drawer unit, CPU stand, cable manager, foot rest etc complete.		
	Top and Front part of counter: 1500mm (5') height of front part consists Different thickness & levels to be maintained in flexible ply up-to 750mm (2'-6")as per design. The top portion will be in bent shape from 300mm to 750mm (1' to 2'-6") level and to be finished with 6mm thk. white corian (dupoint or e.). thickness of the table top will be 25mm excluding corian.the remaining bottom portion will have 4mm thk. Saint gobain aqua blue back painted glass on 18mm thk. Exterior grade MDF board as per design. the bottom portion will be 50mm recessed and have provision for LED striped light over it. the internal portion will be painted with oil paint. 12mm thk. glass will be fixed on top of counter upto 1500mm level including polishing of edge, cutting of transaction hole etc. complete.		
	Drawer unit: making drawer unit of 725mm (H) x 400mm (W) x 500mm (D) (2'-5"H X 16"W X 1'-9"D) . The unit will be made in 18mm thk. exterior grade MDF board Considering 3 drawers with pariscopic channel, partition for cash in upper drawer with auto lock system, drawer fascia will have frosty white solid core laminate selected by architect, wooden beading, handles & hardware etc. complete as per design.		
	Side Top: 1350mm & 2100mmX300mm (4'-6" & 7' (L)X 1' (D)) and 25mm (1") thick top to be made with 12+12 mm exterior grade MDF and covered with 6 mm thk. White corian as per design. The edge will also be finished with corian. Bottom area will be painted with whie oil paint.		
6	Half partition (including door)	15.00	sq.mt.

	<p>Providing and fixing low ht double skin Partitions. Low ht solid and glazed Partitions as per specification including pattern in lamination, complete as per drawings and instructions. The rate shall be inclusive of all the necessary hardware, providing suitable doors at all locations wherever required with SS approved hardware such as handles, stoppers, locks, etc complete. area of the doors shall be treated as partition & measured along with partition area only. Main frame - 50 mm x 25mm Aluminium section of 1.5 mm thk vertical and horizontals at 610mm X 610mm (2'-0" x 2'-0"). Centre spacing approx extra frame below slab soffit for conduit to run above. All verticals secured to ceiling. Skin - Both side with 8mm thk Exterior Grade MDF Board screwed to frame work on both sides with joints as shown or directed. The rate shall be inclusive of Patta with grooves, borders, bottom, middle & top as advised by bank. For Glazing Skin - 12 mm thk plain modi float glass Straight / segmented glass fixed with 32x10mm thk T.W. moulding and 900mm (3'-0") high solid portion as shown in the drawing or as directed by Architect. Finishing - Both side finished in 1.0 mm thk Laminate as shown or directed by Bank. Other exposed areas to be polished/painted as directed by architect or bank's engineer.</p>		
	<p>Partition: Making 1500mm (5'-0") high partition where 900mm (3') height of in double skined with internal wooden framing and covered with 8mm thk Exterior Grade MDF Board on both sides includes laminate as per selection on all sides, necessary hardware etc. complete.</p>		
	<p>Glass: fixing 12mm thk. Clear glass from 900mm to 1500mm (3'-0" to 5'-0") in wooden framing and beading including polishing of glass edges and necessary hardware etc. complete as per design.</p>		
	include night latch - 3nos.		
7	Full height partition (including door)	39.00	sq.mt.
	<p>Providing and fixing Full ht. partly glazed & partly solid partitions as per specifications including skirting, complete as per drawings and instructions. Complete in all respects. The rate shall be inclusive of the necessary hardware, providing suitable doors at all locations wherever required with SS approved hardware such as handles, mortise latches or tubular latches etc complete. Area of the doors shall be treated as partition & measured along with partition area only. Main frame will be 50X25X1.5mm aluminium to be fixed at 610mm X 610mm (2'X2') centre spacing on vertical & horizontal directions. All vertical support will be fixed to the ceiling. Skin - Both side with 8mm thk Exterior Grade MDF Board screwed to frame work on both sides with joints as shown or directed. The rate shall be inclusive of Patta with grooves, borders, bottom, middle & top as advised by bank. For Glazing Skin - 10/12mm thk toughen glass Straight / segmented glass fixed with 32x10mm thk T.W. moulding and 900mm (3'-0") high solid portion as shown in the drawing or as directed by Architect. Finishing - Both side finished in 1mm thk Laminate (sunmica (straight wood (e 976/1976)) as shown or directed by Bank. Other exposed areas to be</p>		

	polished/painted as directed by architect or bank's engineer.		
	Door: making and fixing door in width of 3' with 2" thick wooden framing in width of 5".8mm thk. clear glass to be fixed in middle of the frame. The door also includes door closer Door closer (closer powersize- 4, grade 1 with 20,00,000 cycles, 60% efficiency) (Everite/Ozone), handle (SS BRUSH FINISHED 316 GRADE 8" LONG – HETTICH, DUNEX), Lock (GODREJ, EBCO,DORST,MP 300 SS with 3 keys),stoper, necessary hardware, polish work etc. complete.		
8	Accountant Table	1.00	nos.
	Making accountant's table of 750mm(H) X 750mm(W) x 1300mm (2'-6"(H)X2'-6"(W)x4'-4"(L)) with ply, laminate, necessary hardware,lock, handle etc. complete.		
	Table top : 30mm thk. Table top will be made of 18mm+12mm exterior grade MDF board. The top and sides to be after finished with 4mm thk. Teak Veneer with high gloss PU. the bottom surface will be finsihed with base white oil paint. All corners will have 45 degree joint in veneer.		
	Table side: 30mm (1-1/2") table side will be made with 18+12mm exterior grade MDF to be finished with 1mm thick solid core frosty white laminate on external visibal surfaces & edges.		
	Modesty panel: modesty panel will be made of 12mm thk. Exterior grade MDF board of size shown in drawing finished with 1mm thk solid core frosty white laminate. The back side will be finished with base white oil paint.		
	Drawer unit: making drawer unit of 725mm(H) x 400mm (W) x 500mm (D) (2'-5"(H)x16" (W)x 1'-9" (D)) . The unit will be made in 18mm thk. Exterior grade MDF board Considering 3 drawers with parisopic channel, drawer fascia will have 1 mm thick solid core frosty white laminate as selected by architect, wooden beading, handles & hardware etc. complete as per design.		
	Side Top: 1350mm X300mm (4'-6" (L)X 1' (D)) and 30mm thick top to be made with 18+12 mm exterior grade MDF and covered with 4 mm thk. Teak veener with high gloss finish. The edge will also be finished with veener. All corners will have 45 degree joint in veneer.		
9	Officer table with side unit	1.00	nos.
	Making officer's table of 750mm(H) X 750mm(W) x 1500mm(L) (2'-6"(H)X2'-6"(W)x5'-0"(L))with ply, laminate, necessary hardware,lock, handle etc. complete.		

	<p>Table top : 30mm thk. Table top will be made of 18mm+12mm exterior grade MDF board. The top and sides to be after finished with 4mm thk. Teak Veneer with high gloss PU. the bottom surface will be finished with base white oil paint. All corners will have 45 degree joint in veneer.</p>		
	<p>Table side: 30mm (1-1/2") table side will be made with 18+12mm exterior grade MDF to be finished with 1mm thick solid core frosty white laminate on external visibal surfaces & edges.</p>		
	<p>Modesty panel: modesty panel will be made of 12mm thk. Eterior grade MDF of size shown in drawing finished with 1mm thk solid core frosty white laminate. The back side will be finished with base white oil paint.</p>		
	<p>Drawer unit: making drawer unit of 725mm(H) x 400mm (W) x 500mm (D) (2'-5"(H)x16" (W)x 1'-9" (D)) . The unit will be made in 18mm thk. Exterior grade MDF board Considering 3 drawers with pariscopic channel, drawer fascia will have 1 mm thick solid core frosty white laminate as selected by architect, wooden beading, handles & hardware etc. complete as per design.</p>		
	<p>Side unit:- Providing and fixing of side unit with openable shutters in 3 equal parts. side top and front edge will be covered with 4mm thk. teak veneer with high gloss PU finish. top and sides will be kept in level with table top as per drawing. The thickness of the front edge will be kept 30 thk. The unit with shutters will be 1350mm(L) x 400mm (W) x 650mm (H) (4'-7"(L) x 16" (W) x25-1/2" (H)) with internal shelves, 1mm thick white laminate as per selection & approval, hardware & teak wood beading as per the requirement of drawer unit. the internal surfaces will be painted with oil paint.</p>		
10	Officer table without side unit	1.00	nos.
	<p>Making officer's table of 750mm(H) X 750mm(W) x 1500mm(L) (2'-6"(H)X2'-6"(W)x5'-0"(L))with ply, laminate, necessary hardware,lock, handle etc. complete.</p>		
	<p>Table top : 30mm thk. Table top will be made of 18mm+12mm exterior grade MDF board. The top and sides to be after finished with 4mm thk. Teak Veneer with high gloss PU. the bottom surface will be finished with base white oil paint. All corners will have 45 degree joint in veneer.</p>		
	<p>Table side: 30mm (1-1/2") table side will be made with 18+12mm exterior grade MDF to be finished with 1mm thick solid core frosty white laminate on external visibal surfaces & edges.</p>		
	<p>Modesty panel: modesty panel will be made of 12mm thk. Exterior grade MDF of size shown in drawing finished with 1mm thk solid core frosty white laminate. The back side will be finished with base white oil paint.</p>		

	Drawer unit: making drawer unit of 725mm(H) x 400mm (W) x 500mm (D) (2'-5"(H)x16" (W)x 1'-9" (D)) . The unit will be made in 18mm thk. Exterior grade MDF board Considering 3 drawers with pariscopic channel, drawer fascia will have 1 mm thick solid core frosty white laminate as selected by architect, wooden beading, handles & hardware etc. complete as per design.		
11A	UPS Room Door	1.00	no.
	Providing & Fixing of 750mm x 2100mm, 38mm door with door closer, S.S handle,cylindrical lock, tower bolt fixed with 13mm (1/2") th wooden beading patti on perimeter. The door to be made from 25mm X 38mm (1"x1.5") aluminium frame and finished with 6mm fire resistant material (i.e hilux board) on both sides and finished with satin finish acrylic paint on all sides as per architect's instructions. Door to have 8mm (305mm X 1372mm) (1'-0"x4'-6") glass as viewing panel.		
11B	UPS Partition	6.20	sq.m.
	Providing & Fixing full heigh partition for UPS room. The partition to be made from 25mm X 50mm (1"x 2") aluminium frame and finished with 6mm fire resistant material (i.e hilux board) on both sides and finished with satin finish acrylic paint on all sides as per architect's instructions.		
12	Flush door shutters (685mm to 750mm)	1.00	Nos.
	Supplying and fixing 38mm thk chilwood flush door of approx size 685mm -750mm x 2133mm (2'-3" - 2'-6"x7') with Door closer (closer powersize- 4, grade 1 with 20,00,000 cycles, 60% efficiency) (Everite/Ozone), SS handle, cylindrical lock, tower bolt fixed wth 1/2" teakwood beading on perimeter. The door should be finished with 1mm thk laminate on both sides as per architect's design & instruction. All exposed wood work to be finished with oil paint.(All hardware in Godrej/Hettich/ Ebco made)		
13	electrical panel cabinet	2.60	sq.mt.
	Providing and fixing to 2 nos. of cement particle board shutters in thickness of 18 mm as to cover electrical main panel, 5mm clear glass as viewing panel, fixed S.S. Jali etc. complete. The shutters to be fixed with auto hinges (Hettich, plumb made), SS handles, lock and laminate over exposed surface and side members also etc. complete.		
14	Center column panelling	4.00	sq.mt.

	Panelling & boxing - panelling / wall cladding of central columns in the banking hall with 12mm thick Exterior Grade MDF Board including framing, exposed surface to be treated with 1 mm thick approved laminate as per selection as per detail drawing, central part to be finished with 8mm CNC MDF jali cutting work with white high gloss PU paint on 4mm thick aqua blue back painted glass as per design.		
15	Column panelling	6.00	sq.mt.
	Panelling & boxing - panelling / wall cladding of other remaining columns in the banking hall with 12mm thick Exterior Grade MDF Board approved plywood including framing, exposed surface to be treated with 1 mm thick approved laminate as per selection.		
16	Wall paper	6.00	sq.mt.
	Providing and applying wall paper with approved brand and quality.(Marshall, Aarcee, Fabwall). Basic rate is Rs. 100/- per sqft.		
17	Wall panelling behind single window- digital wall	9.00	sq.mt.
	Providing and fixing panelling on wall having aluminium framing of 50mmX50mmX1.2mm thick at maximum 400mm (2') c/c both ways covered with 8mm thick exterior grade MDF board. The panelling will have recessed light on top edge. All faces will be finished with high gloss PU paint as per selection. The joints between to MDF will be in regular interval and have 4mm groove. Only finished visible surface area shall be measured for payment purpose.		

CLVL : 2801.11mm

BBLVL : 2438.4mm

DROP SLAB LVL : 2313.4mm

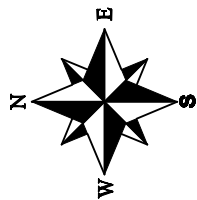

SBI,
PARLEPOINT
BRANCH
PROPOSED
LAYOUT

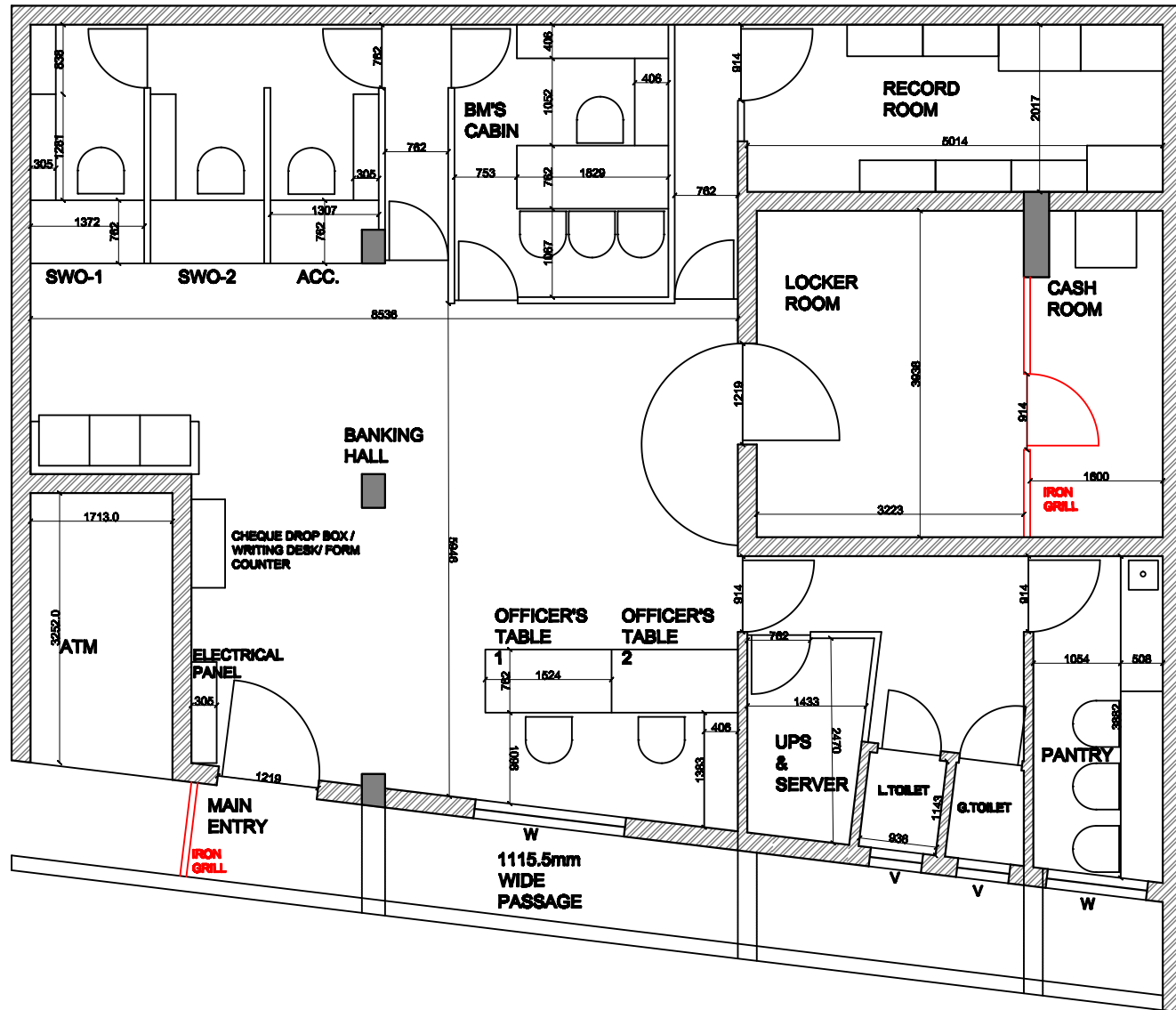

1. ALL DIMENSIONS ARE IN FEET- INCHES & ARE TO BE READ NOT MEASURED.
2. DISCREPANCY FOUND IN DRG SHOULD BE BROUGHT TO THE ARCHITECT'S NOTICE IMMEDIATELY.
3. ARCH. DWGS. TO HAVE PRECEDENCE OVER STRL. DWGS. FOR POSITIONS AND DIMENSIONS.
4. FINISHED GROUND FLOOR IS AT 100'
5. LARGE SCALE DRGS TO HAVE PRECEDENCE OVER SMALL SCALE DRGS
6. PLINTH OF THE EXISTING BUILDING IS AT 100'.

ABBREVIATIONS

DATE REVISION

REVISIONS

SBI, PARLE POINT BRANCH
PROPOSED LAYOUT

PROJ. NO.
1016
AWD. NO. 01

CHECK BY: DRAWN BY: PARTH DATE: 08-05-18 SCALE: NTS

ARCHITECT: VISHAL PAREKH
409/ KINARD, NR. MAJKAI POOL, NANPURA, SURAT-1
PH. NO: 98763 17899 e-mail: vishalparekh@yahoo.com

CLVL : 2801.11mm

BBLVL : 2438.4mm

DROP SLAB LVL : 2313.4mm

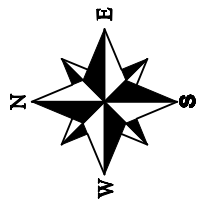

SBI,
PARLEPOINT
BRANCH
PROPOSED
FALSE
CEILING
LAYOUT

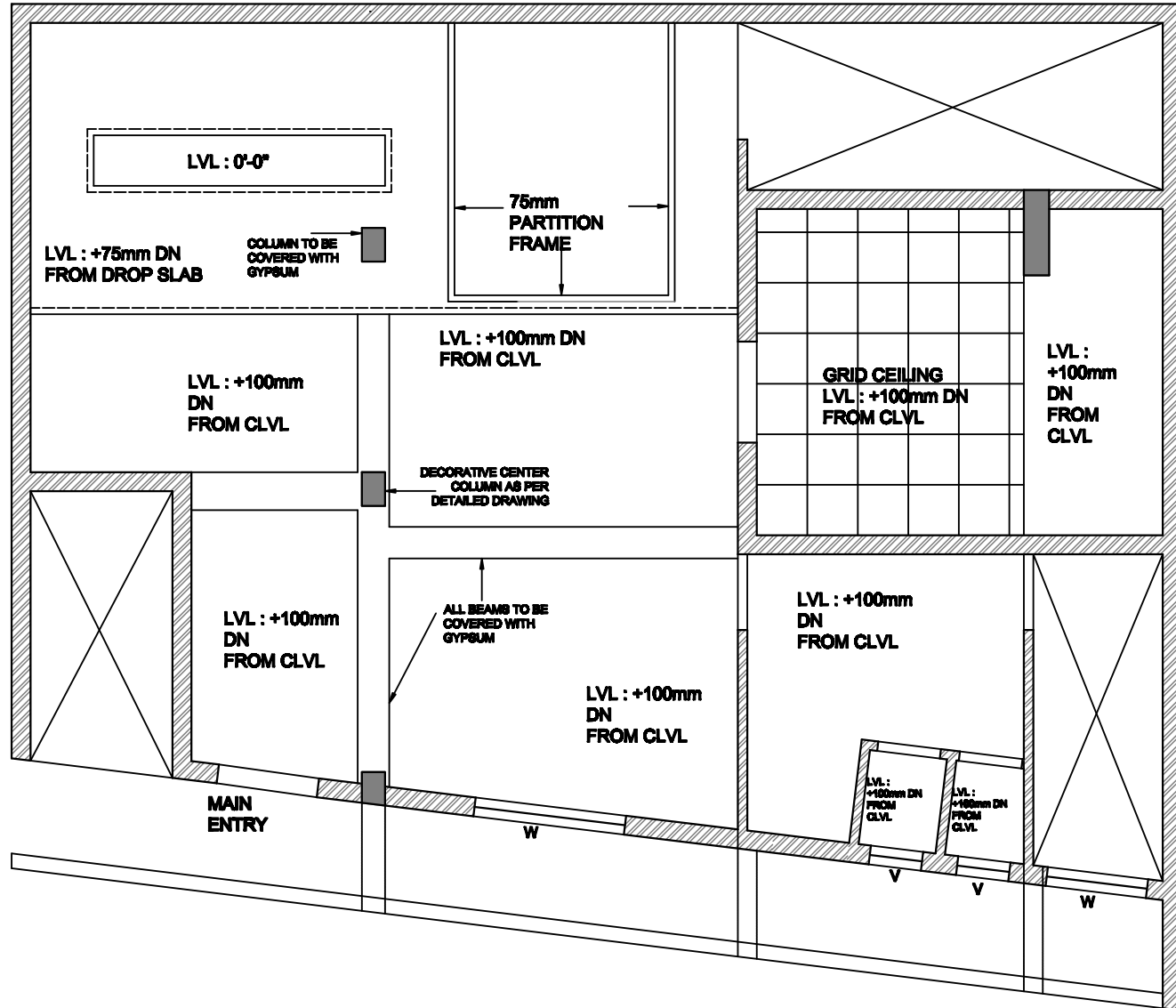

1. ALL DIMENSIONS ARE IN FEET- INCHES & ARE TO BE READ NOT MEASURED.
2. DISCREPANCY FOUND IN DRG SHOULD BE BROUGHT TO THE ARCHITECT'S NOTICE IMMEDIATELY.
3. ARCH. DWGS. TO HAVE PRECEDENCE OVER STRL. DWGS. FOR POSITIONS AND DIMENSIONS.
4. FINISHED GROUND FLOOR IS AT 100'
5. LARGE SCALE DRGS TO HAVE PRECEDENCE OVER SMALL SCALE DRGS
6. PLINTH OF THE EXISTING BUILDING IS AT 100'.

ABBREVIATIONS

REVISIONS

DATE REVISION

SBI, PARLE POINT BRANCH
PROPOSED FALSE CEILING LAYOUT

CHECK BY: DRAWN BY: PARTH DATE: 08-08-18

ARCHITECT: VISHAL PAREKH
408/ KINARO, NR. MAKKAI POOL, NANPURA, SURAT-1
PH.NO: 98783 17890 e-mail: vishalparekh@yahoo.com

PROJ.NO.
1016
AWD.NO. 01

SCALE: NTR

AUTO LOCK -
EBCO - P-ALL1-22



MULTI PURPOSE
LOCK- EBCO -
E-MPL1-22



NIGHT LATCH -
EUROPA 8010 NS



HINGES - S.S.
MATT FINISH -
EBCO



CHANNEL -
EBCO- BMDS 35



HANDLES -
SS-202 MATT
FINISH

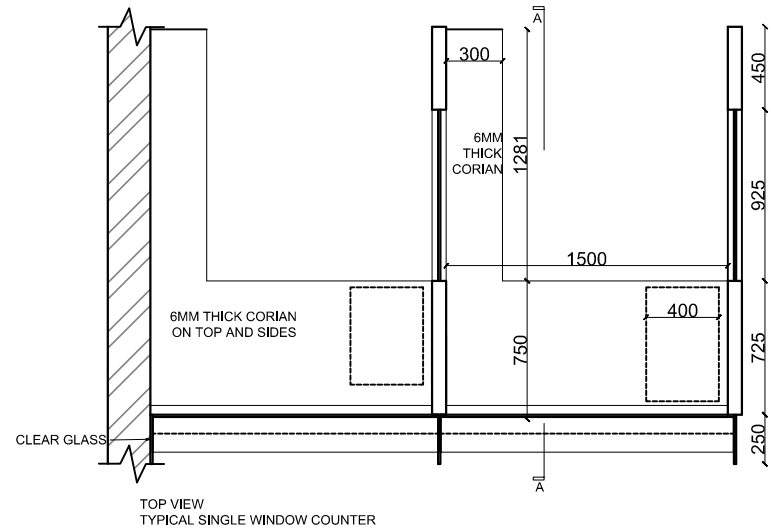
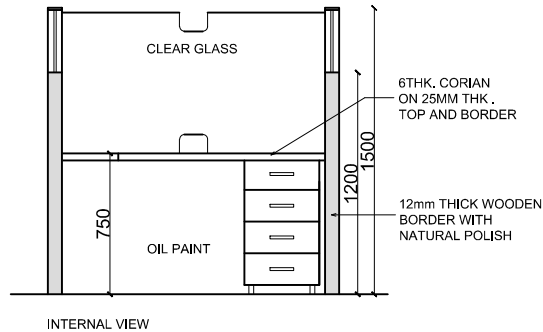
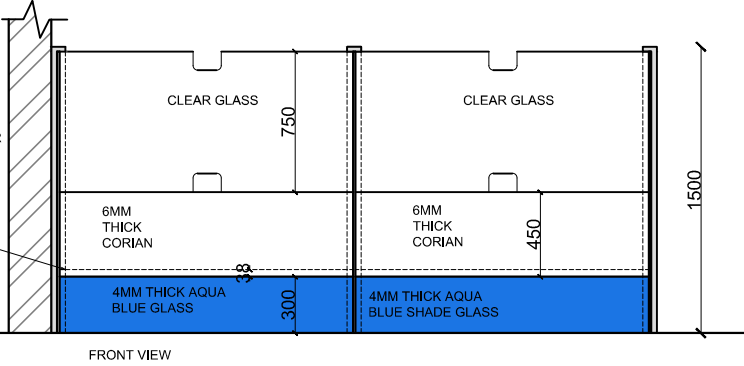
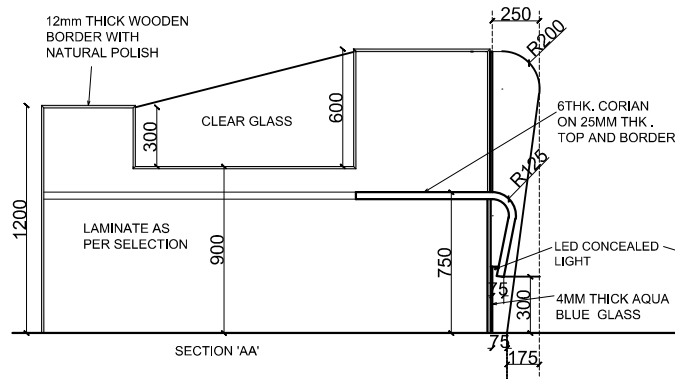

APPROVALS

CONSULTANT

ARCHITECT

SITE COORDINATOR

NOTES

1. ALL DIMENSIONS ARE IN FEET- INCHES & ARE TO BE READ NOT MEASURED.
2. DISCREPANCY FOUND IN DRG SHOULD BE BROUGHT TO THE ARCHITECT'S NOTICE IMMEDIATELY.
3. ARCH. DWGS. TO HAVE PRECEDENCE OVER STRL. DWGS. FOR POSITIONS AND DIMENSIONS.
4. FINISHED GROUND FLOOR IS AT 100'
5. LARGE SCALE DRGS TO HAVE PRECEDENCE OVER SMALL SCALE DRGS
6. PLINTH OF THE EXISTING BUILDING IS AT 100'.

ABBREVIATIONS	DATE	REVISION

REVISIONS

DATE	REVISION

SBI-PARLEPOINT BRANCH, SURAT

TYPICAL SINGLE WINDOW COUNTER

CHECK BY: [] DRAWN BY: VISHAL [] DATE:- 02-01-17 SCALE NTS

ARCHITECT: VISHAL PAREKH

409/ KINARO, NR. MAKKAI POOL, NANPURA, SURAT-1

PH.NO: 98793 17886 e-mail: vishalvparekh@yahoo.com

PROJ.NO. 1016

AWD.NO. 07

MULTI PURPOSE
LOCK- EBCO -
E-MPL1-22



HINGES - S.S.
MATT FINISH -
EBCO

CHANNEL -
EBCO- BMDS 35



HANDLES -
SS-202 MATT
FINISH



VENEER-GREENPLY
BURMA TEAK
VENEER

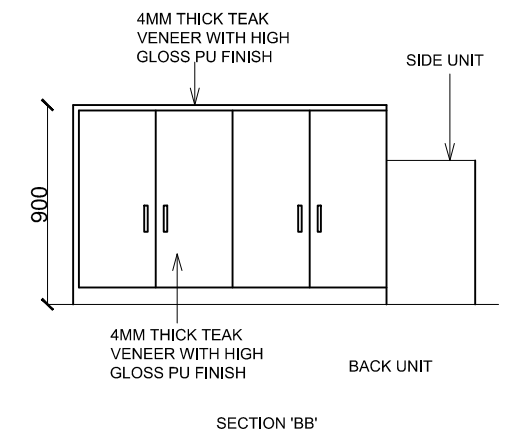
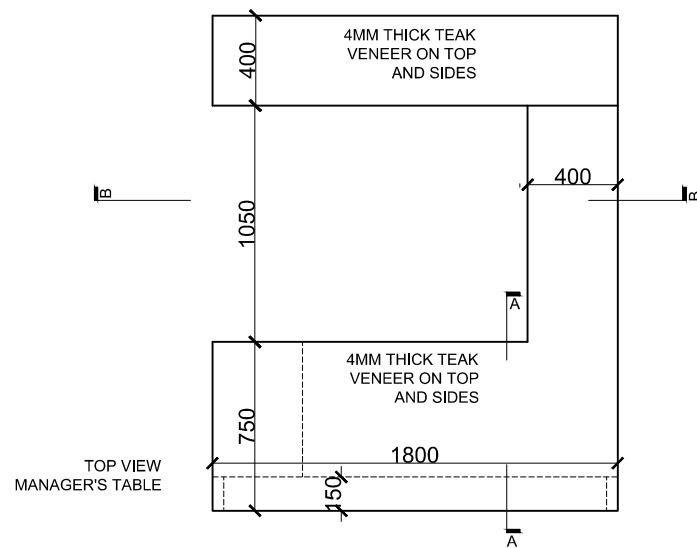
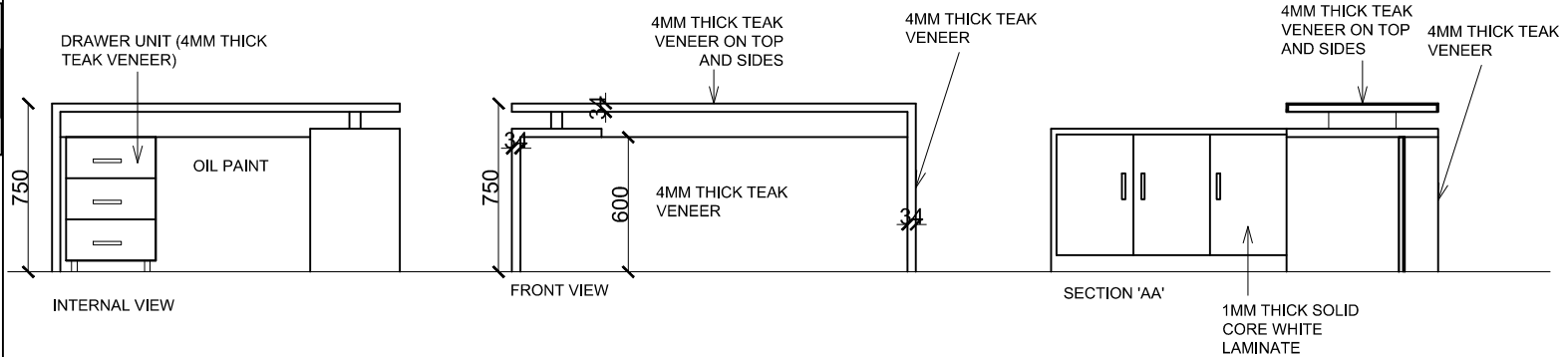

APPROVALS
CONSULTANT
ARCHITECT
SITE COORDINATOR

NOTES
1. ALL DIMENSIONS ARE IN FEET- INCHES & ARE TO BE READ NOT MEASURED.
2. DISCREPANCY FOUND IN DRG SHOULD BE BROUGHT TO THE ARCHITECT'S NOTICE IMMEDIATELY.
3. ARCH. DWGS. TO HAVE PRECEDENCE OVER STRL. DWGS. FOR POSITIONS AND DIMENSIONS.
4. FINISHED GROUND FLOOR IS AT 100'
5. LARGE SCALE DRGS TO HAVE PRECEDENCE OVER SMALL SCALE DRGS
6. PLINTH OF THE EXISTING BUILDING IS AT 100'.

ABBREVIATIONS

REVISIONS
DATE REVISION

SBI-PARLEPOINT BRANCH, SURAT
MANAGER'S TABLE
CHECK BY: [] DRAWN BY: VISHAL [] DATE:- 10-05-19 SCALE NTS
ARCHITECT: VISHAL PAREKH
409/ KINARO, NR. MAKKAI POOL, NANPURA, SURAT-1
PH.NO: 98793 17886 e-mail: vishalvparekh@yahoo.com

PROJ.NO.
1016
AWD.NO. 01
SCALE NTS

NOTE: THIS DRAWING IS THE PROPERTY OF ARCHITECT VISHAL PAREKH & SHOULD NOT BE COPIED, REPRODUCED OR USED FOR ANY PURPOSE THAN SPECIFIED WITHOUT THE PRIOR PERMISSION OF THE ARCHITECT IN WRITING.

MULTI PURPOSE
LOCK- EBCO -
E-MPL1-22



HINGES - S.S.
MATT FINISH -
EBCO

CHANNEL -
EBCO- BMDS 35



HANDLES -
SS-202 MATT
FINISH



VENEER-GREENPLY
BURMA TEAK
VENEER



AICA
LAMINATE-WP172
(DARK COLOUR
AND SHOULD BE
MATCHED WITH
VENEER)

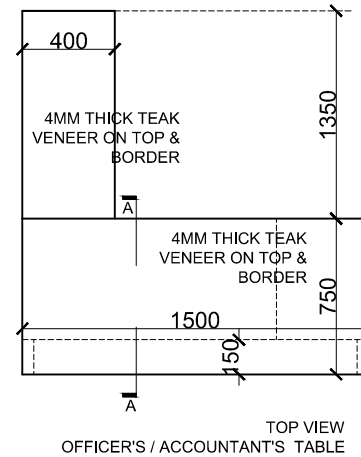
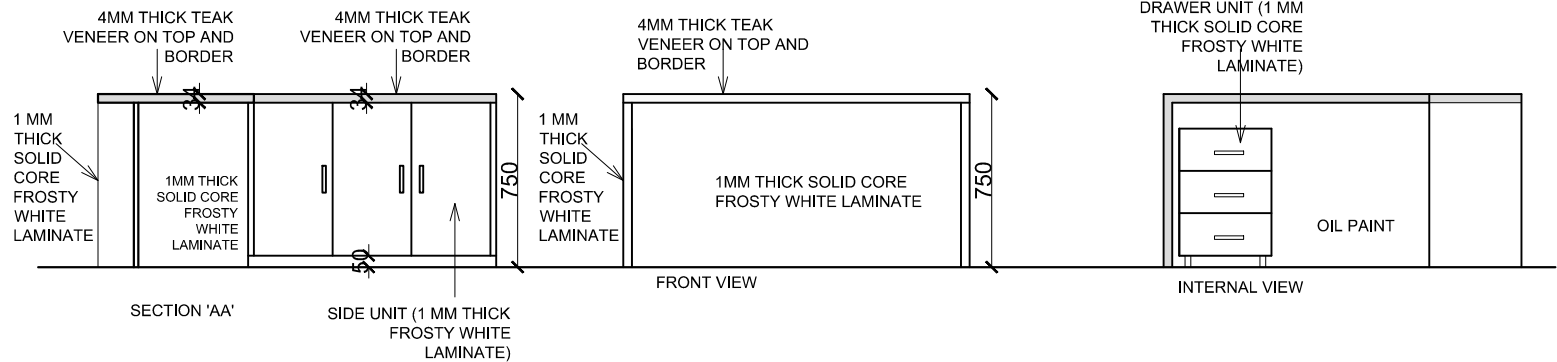

APPROVALS
CONSULTANT
ARCHITECT
SITE COORDINATOR

NOTES
1. ALL DIMENSIONS ARE IN FEET- INCHES & ARE TO BE READ NOT MEASURED.
2. DISCREPANCY FOUND IN DRG SHOULD BE BROUGHT TO THE ARCHITECT'S NOTICE IMMEDIATELY.
3. ARCH. DWGS. TO HAVE PRECEDENCE OVER STRL. DWGS. FOR POSITIONS AND DIMENSIONS.
4. FINISHED GROUND FLOOR IS AT 100'
5. LARGE SCALE DRGS TO HAVE PRECEDENCE OVER SMALL SCALE DRGS
6. PLINTH OF THE EXISTING BUILDING IS AT 100'.

ABBREVIATIONS

REVISIONS
DATE REVISION

SBI-PARLEPOINT BRANCH, SURAT
OFFICER'S / ACCOUNTANT'S TABLE
CHECK BY: [] DRAWN BY: VISHAL [] DATE:- 10-05-19 [] SCALE NTS
ARCHITECT: VISHAL PAREKH
409/ KINARO, NR. MAKKAI POOL, NANPURA, SURAT-1
PH.NO: 98793 17886 e-mail: vishalvparkh@yahoo.com

PROJ.NO.
1016
AWD.NO. 05

